

Verwendungsbereich 410x680x580	Toleranz nach DIN ISO 2768-mK	Oberflächen DIN ISO 1302	Maßstab: 1:10	Gewicht: 82 kg
			Werkstoff	1.4301 AISI 304
Name	Datum	Gas Wassergrill PASADENA		
Bearb. M.B.	17.07.2020			
HEIDEBRENNER		GNIA		A3

Artikel Nr.	P [kW]	P <sub>ges</sub> [kW]	Volumenstrom V [m³/h]	Gasanschluß [Zoll]	Länge Verbrauchsleitung, delta p=0.6mBar [m]
GNIA	1 x 12,8	12,8	1,35	1/2"	20

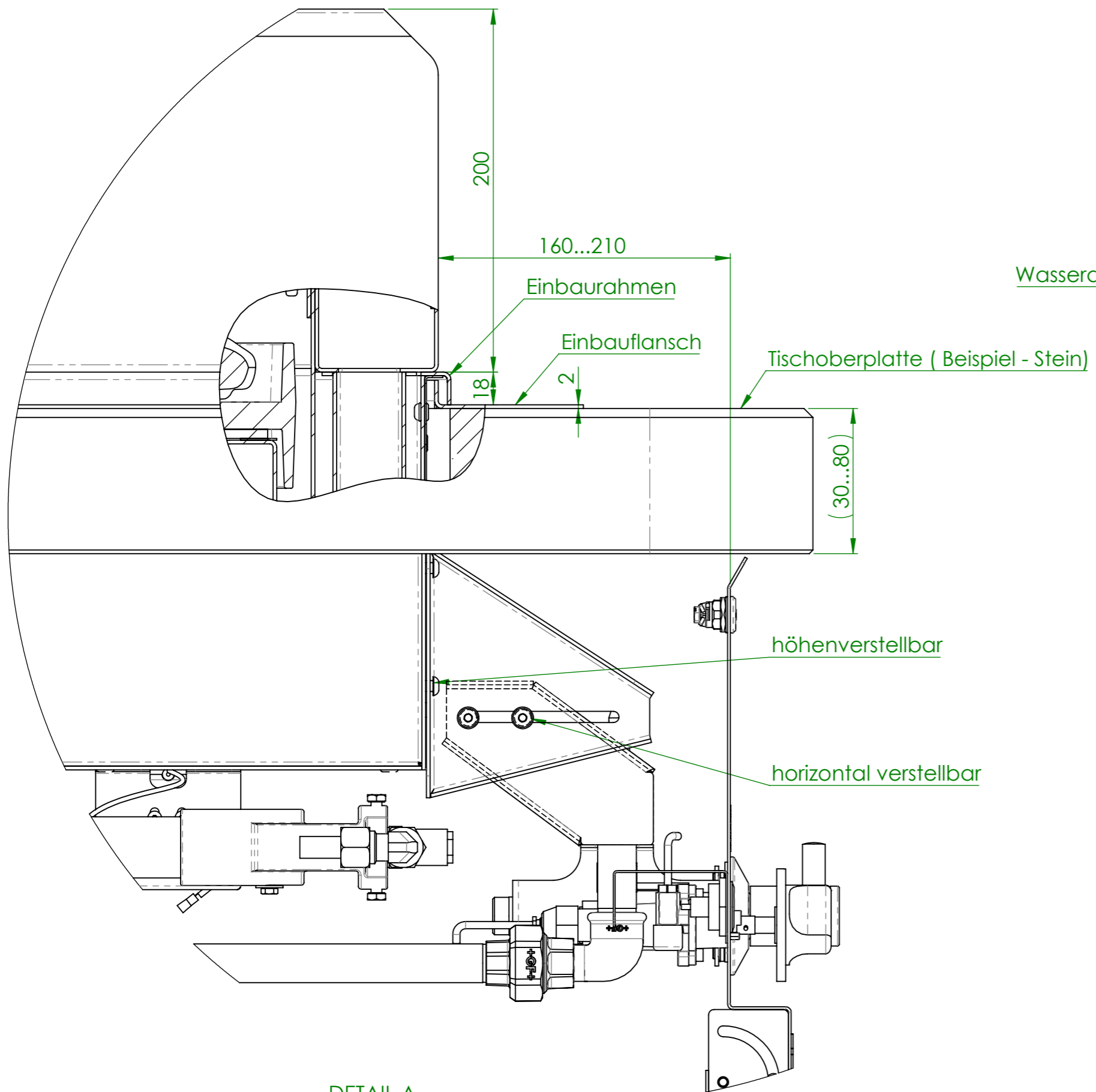

DETAIL A  
SCALE 1 : 2.5

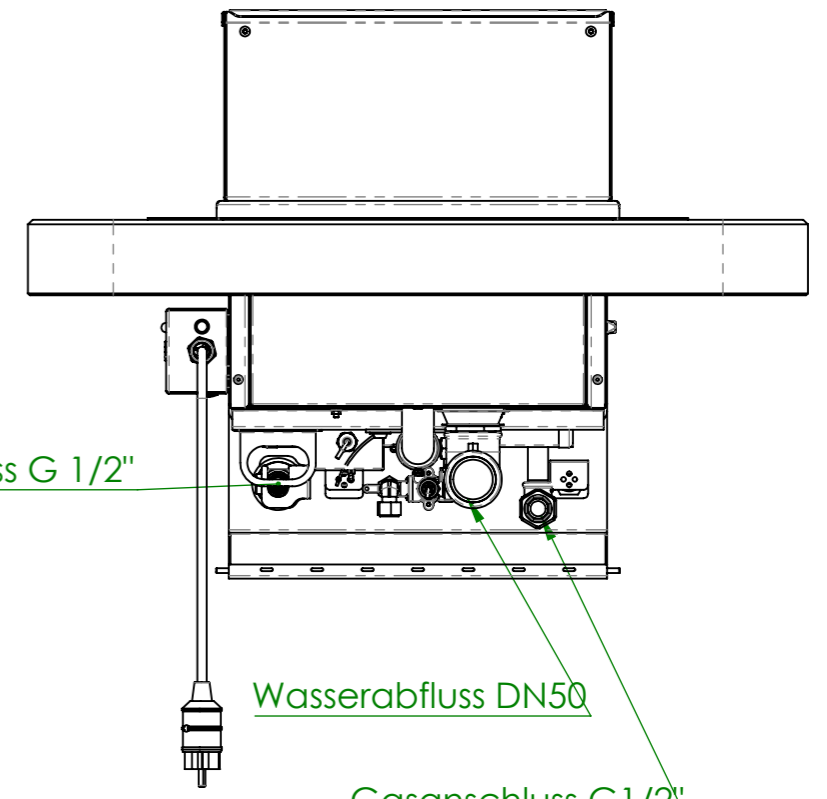

View B

Verwendungsbereich 410x680x580	Toleranz nach DIN ISO 2768-mK	Oberflächen DIN ISO 1302	Maßstab: 1:8	Gewicht: 82 kg
			Werkstoff 1.4301 AISI 304	
Name	Datum	Gas Wassergrill PASADENA		
Bearb. M.B.	17.07.2020			
HEIDEBRENNER		GNIA		A3

### Beispiel Einbflansch

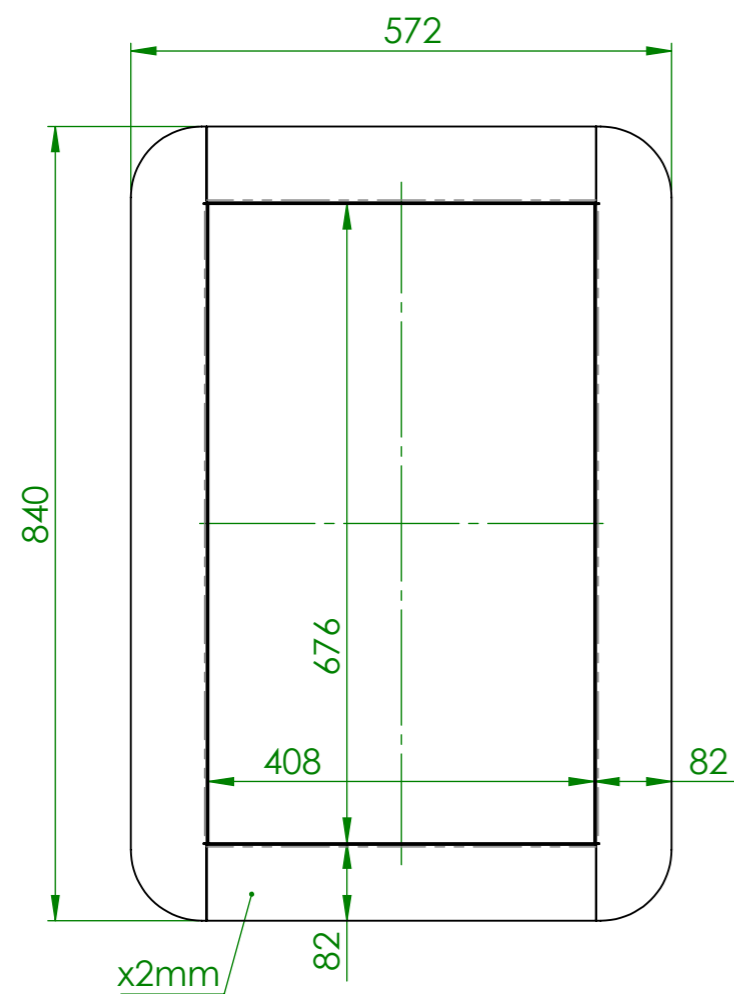

### Größe Ausschnitt für Arbeitsplatte

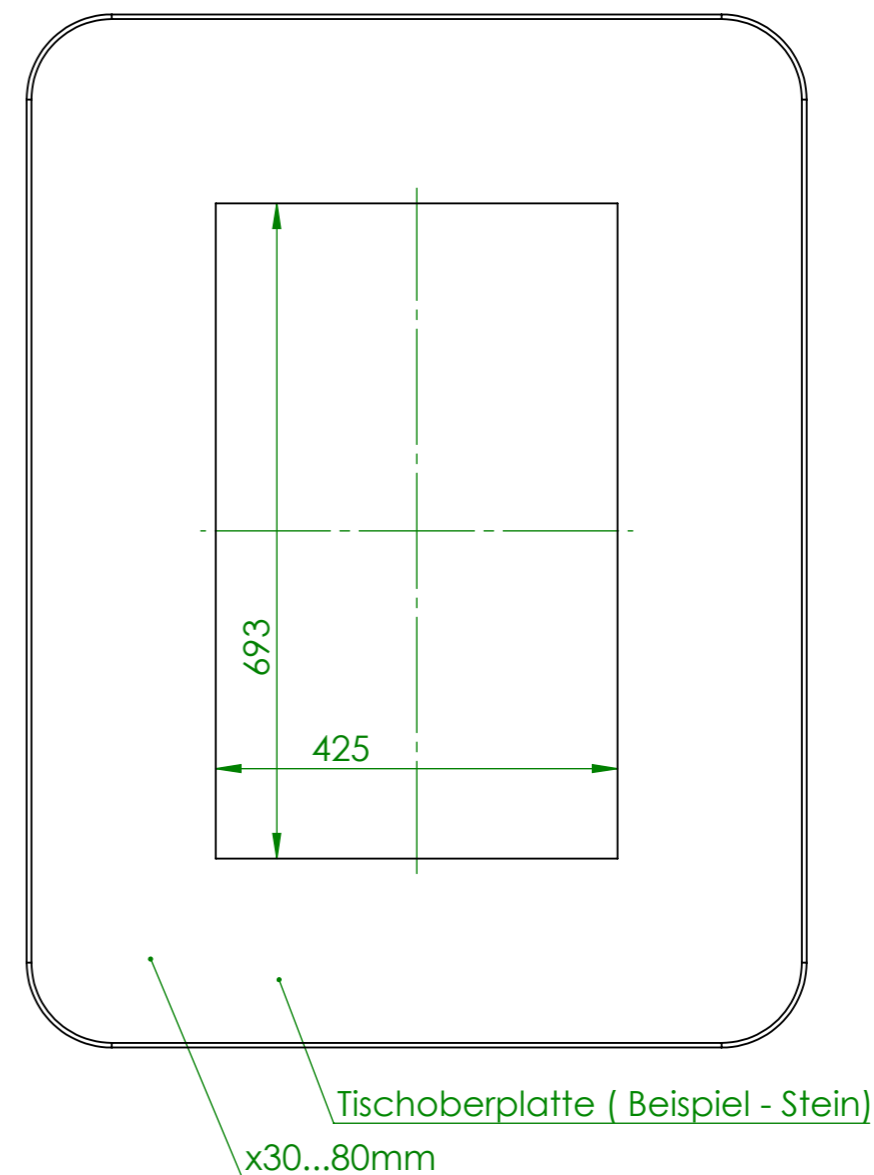

Verwendungsbereich 410x680x580	Toleranz nach DIN ISO 2768-mK	Oberflächen DIN ISO 1302	Maßstab: 1:8	Gewicht: kg
			Werkstoff 1.4301 AISI 304	
Name	Datum	Gas Wassergrill PASADENA		
Bearb. M.B.	17.07.2020			
HEIDEBRENNER		GNIA		A3

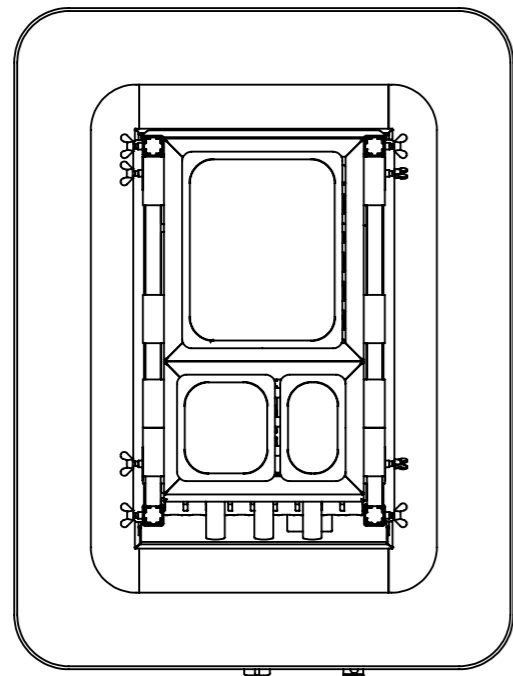
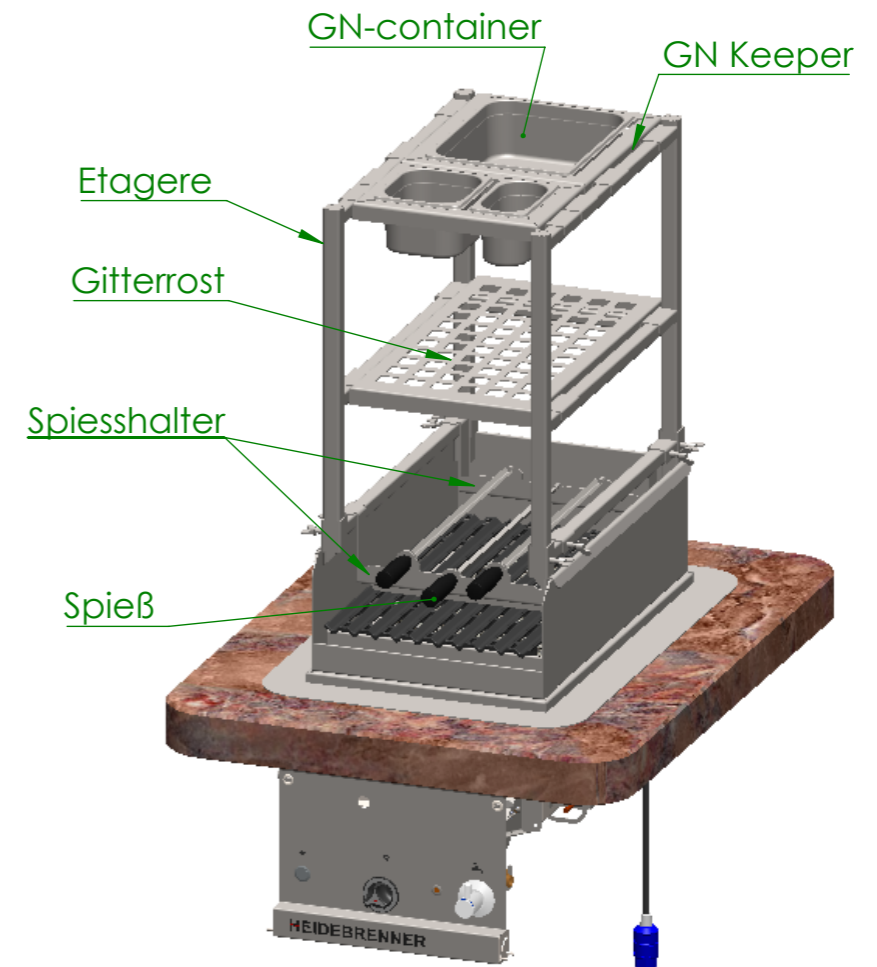
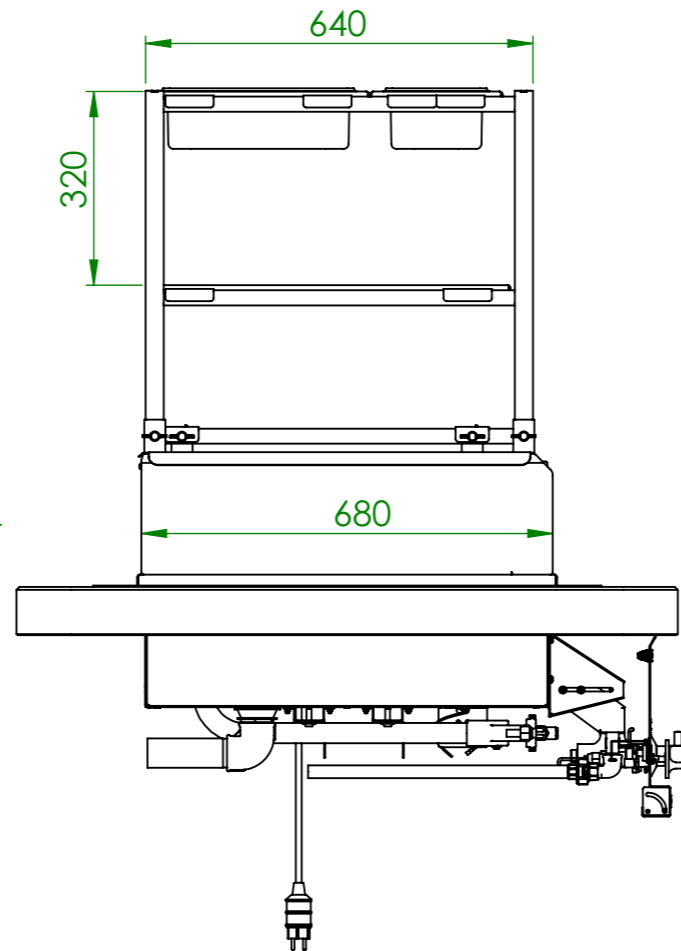
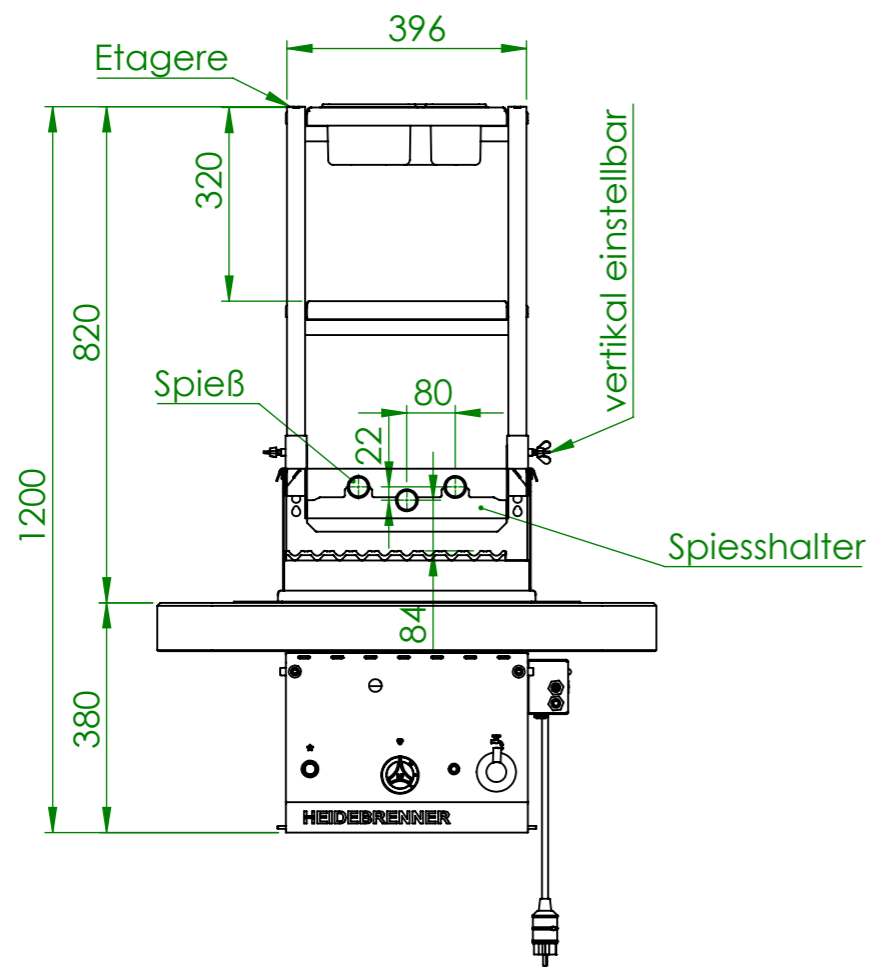

Verwendungsbereich 410x680x1200	Toleranz nach DIN ISO 2768-mK	Oberflächen DIN ISO 1302	Maßstab: 1:12.5	Gewicht: 106 kg
			Werkstoff 1.4301 AISI 304	
Name	Datum	Gas Wassergrill PASADENA		
Bearb. M.B.	17.07.2020			
<b>HEIDEBRENNER</b>		GNIA+Etagere		A3