

Artikel Nr.	HZ	P [kW]	Pges [kW]	Volumenstrom V [m3/h]	Gasanschluß [Zoll]	Länge Verbrauchsleitung [m] delta p=0.6mBar
GNHD	4	12.8	51.2	5.42	1"	6

Verwendungsbereich 1400x1000x750	Toleranz nach DIN ISO 2768-mK	Oberflächen DIN ISO 1302	Maßstab: 1:16	Gewicht: 275.44 kg
			Werkstoff: 1.4301	
Name	Datum	Gas Wassergrill HOUSTON		
Bearb. M.B.	6/17/2020			
HEIDEBRENNER		GNHD		A3

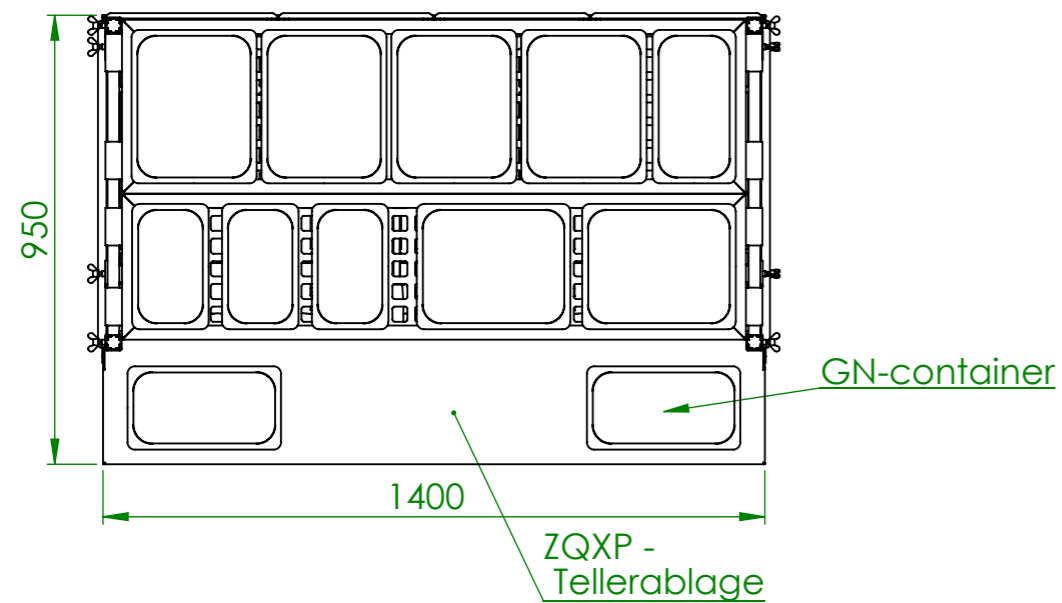
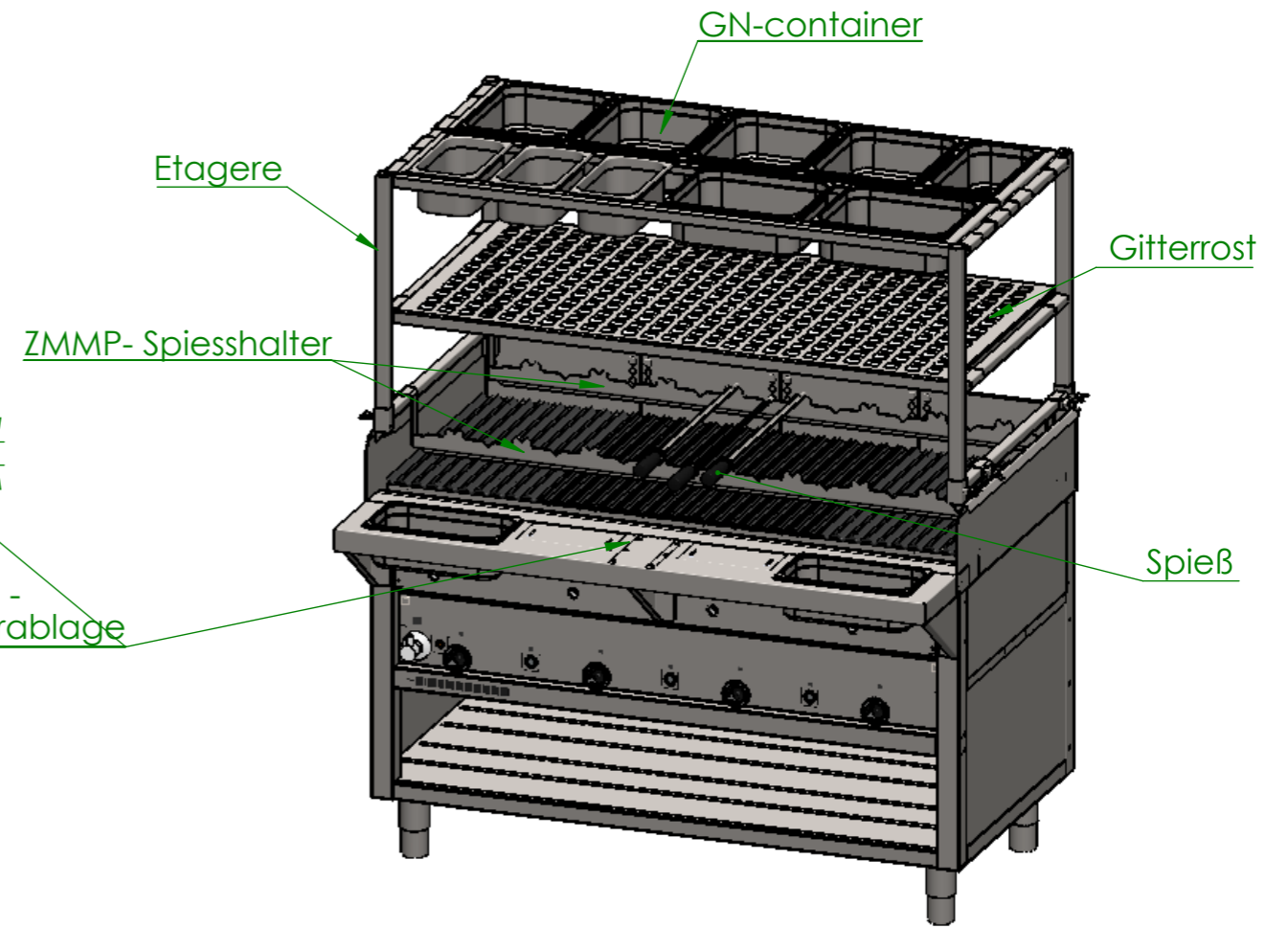
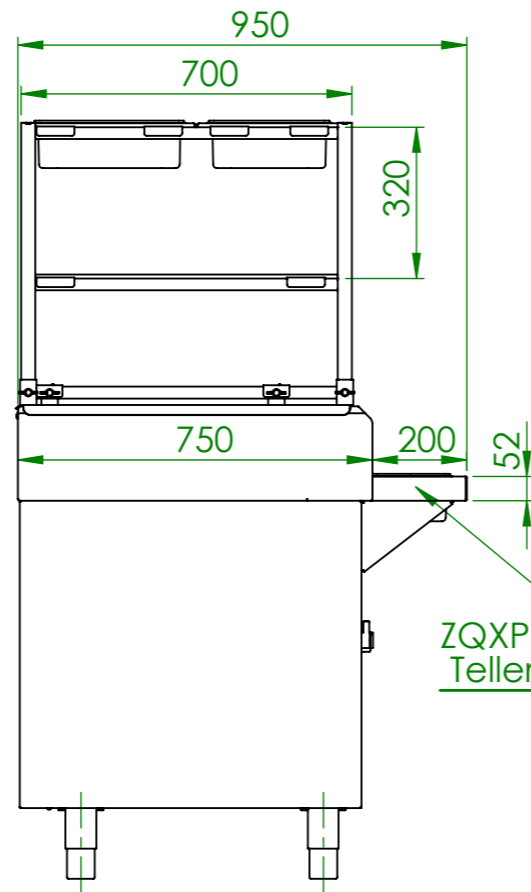
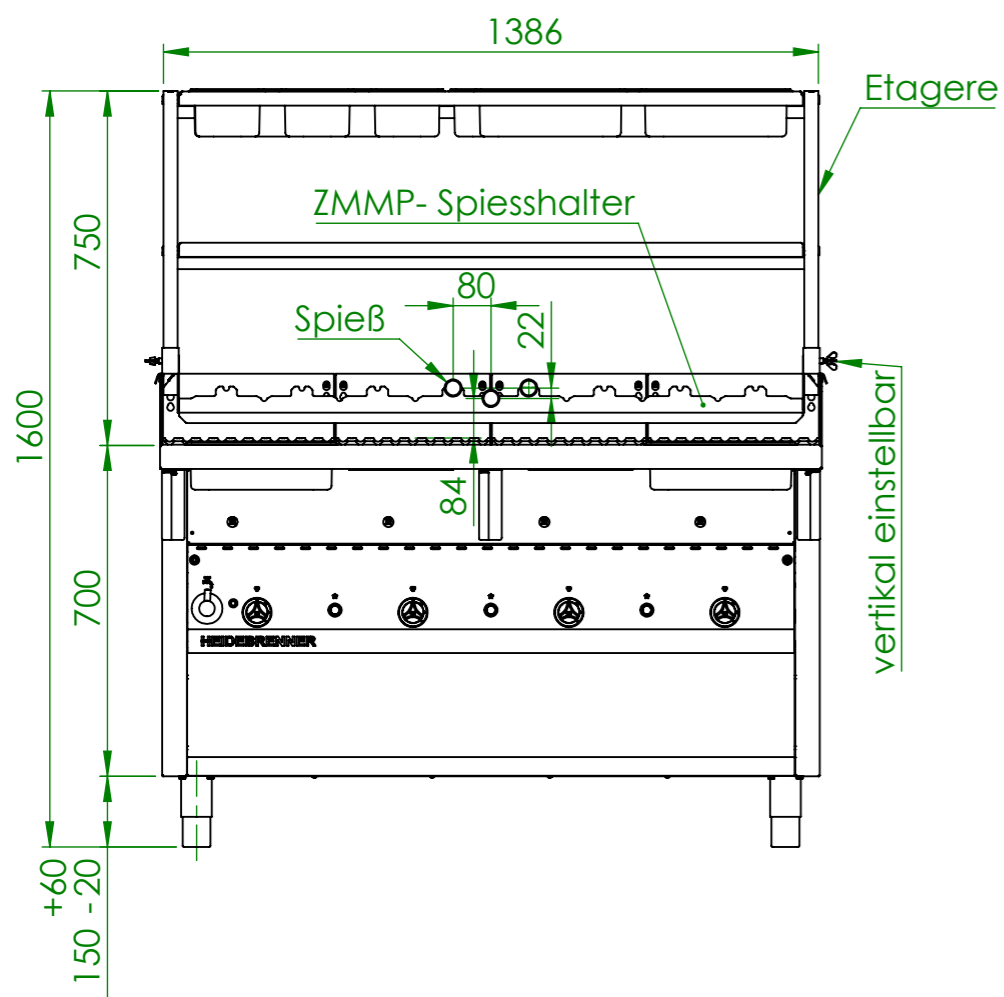

Verwendungsbereich 1600x1400x950	Toleranz nach DIN ISO 2768-mK	Oberflächen DIN ISO 1302	Maßstab: 1:16 Werkstoff 1.4301 AISI 304	Gewicht: 330 kg
Name	Datum	Gas Wassergrill HOUSTON		
Bearb. M.B.	6/17/2020			
HEIDEBRENNER		GNHD+Etagere+GN_keeper		A3