

Menge: 1xStück

POS.	BENENNUNG	BESCHREIBUNG	MENGE
1	ZCUO01-101	Gitterauflage 2/3	1
2	ZCxx-113	U-Profil	4
3	50091	Blindnieten mit Flachrundkopf 5x8	12

Verwendungsbereich 1060x400x30	Toleranz nach DIN ISO 2768-mK	Oberflächen DIN ISO 1302	Maßstab: 1:8	Gewicht: 5.06 Kg
			Werkstoff Material <not specified>	
Name	Datum	Gitterauflage 2/3		
Bearb. M.B.	20/06/2019			
HEIDEBRENNER		ZCUO01		A3

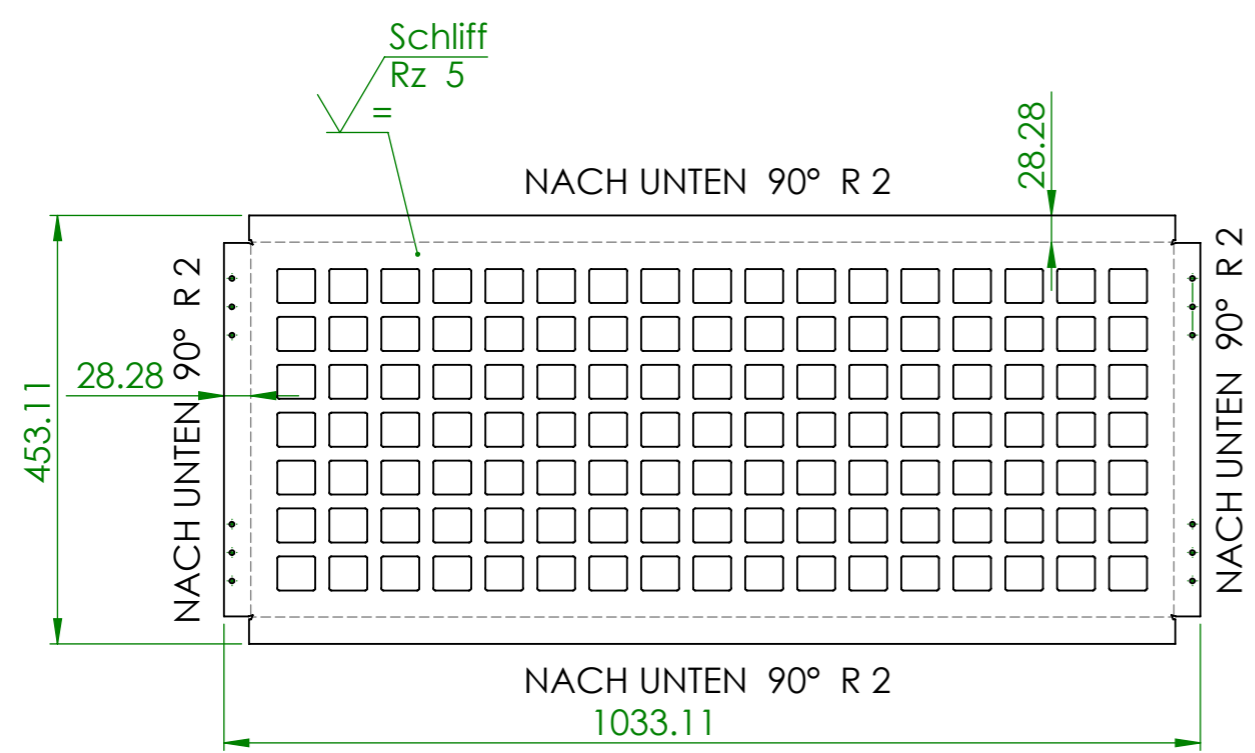
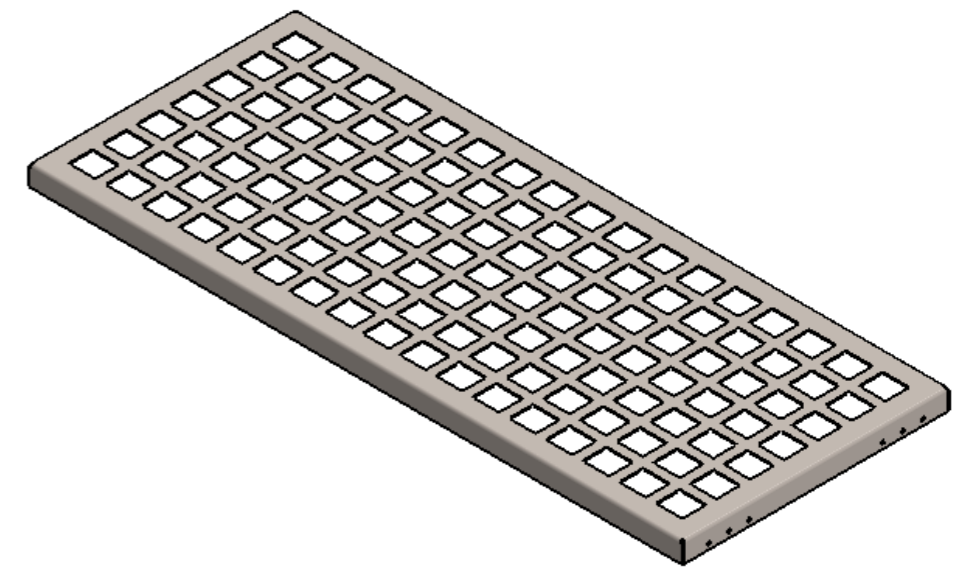
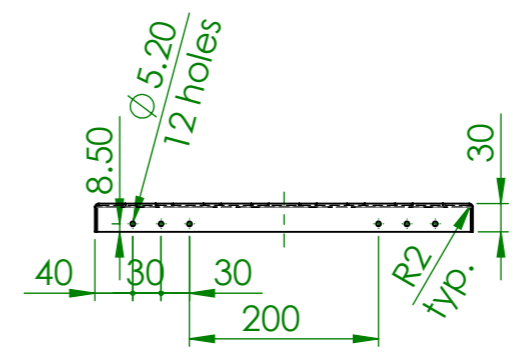
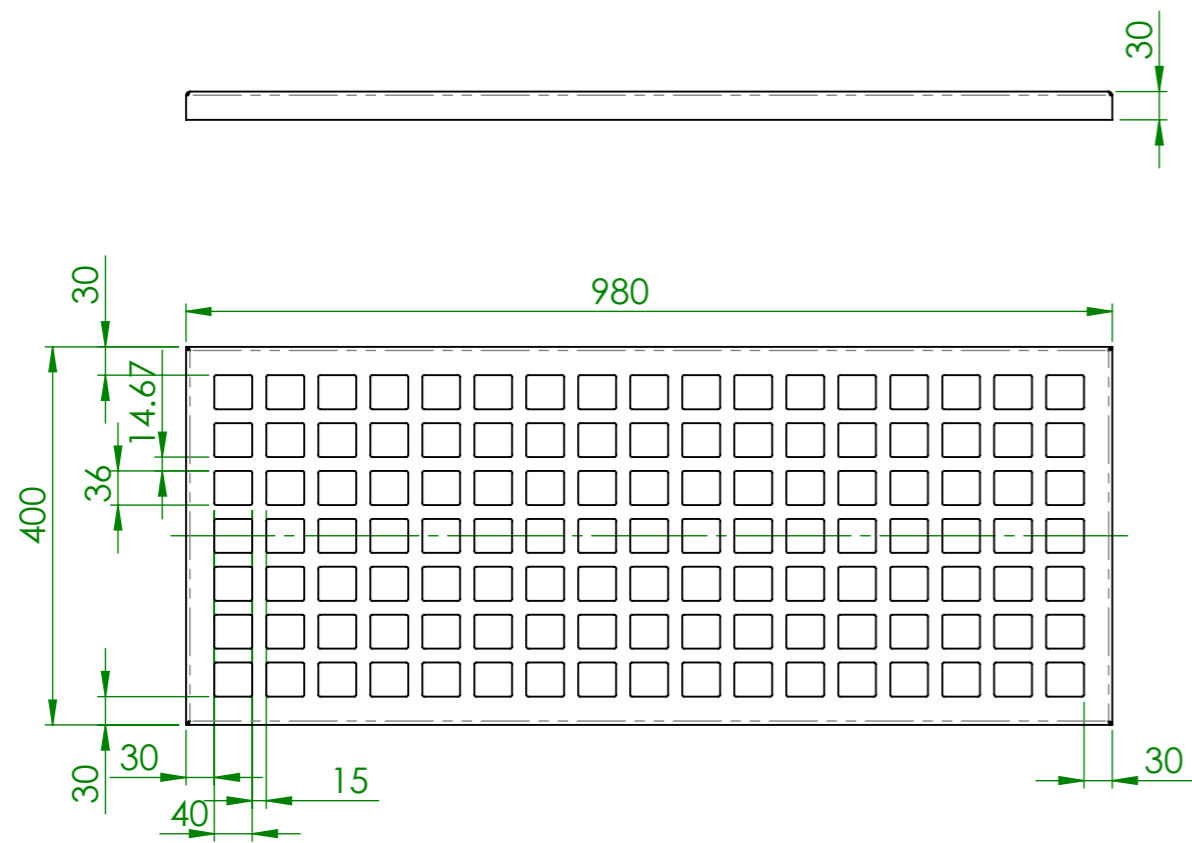

t=2mm; Menge: 4xStück

Verwendungsbereich 980x400x30	Toleranz nach DIN ISO 2768-mK	Oberflächen DIN ISO 1302	Maßstab: 1:8	Gewicht: 4.65 Kg
			Werkstoff 1.4301 (X5CrNi18-10)	
Name	Datum		Etagere Grill	
Bearb. M.B.	20/06/2019			
HEIDEBRENNER			ZCU001 Gitterauflage 2/3 ZCU001 - 101 Gitter blech	
				A3

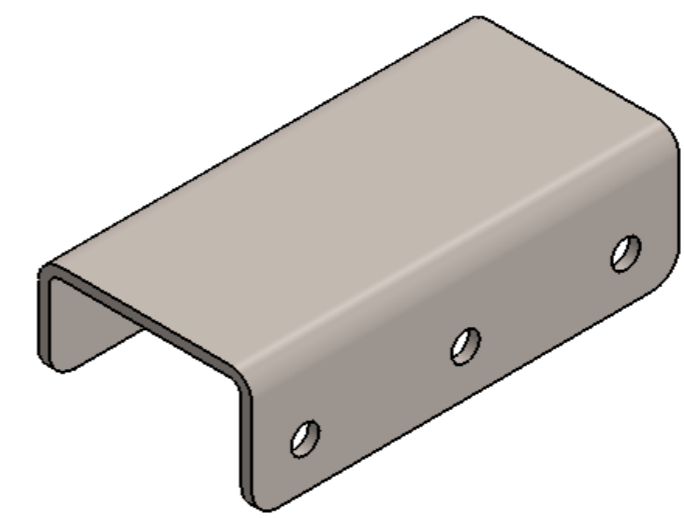
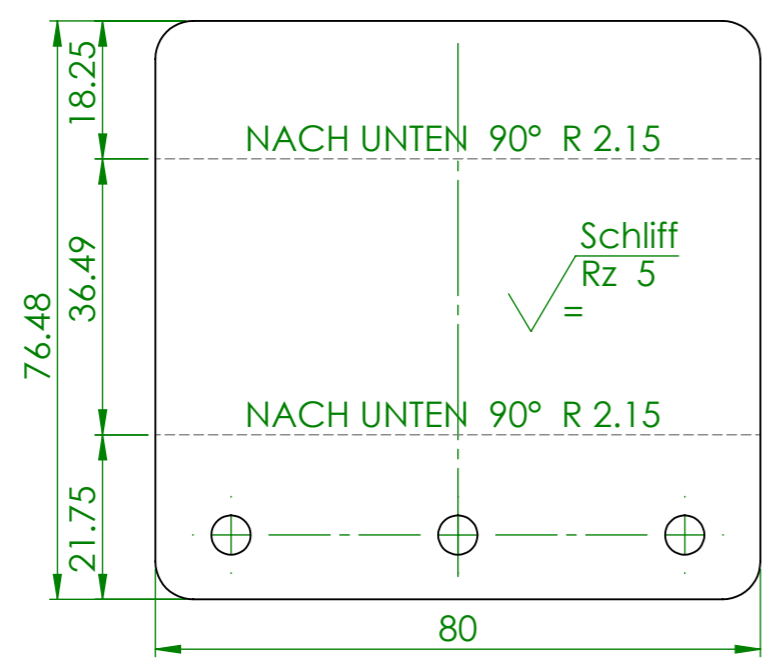
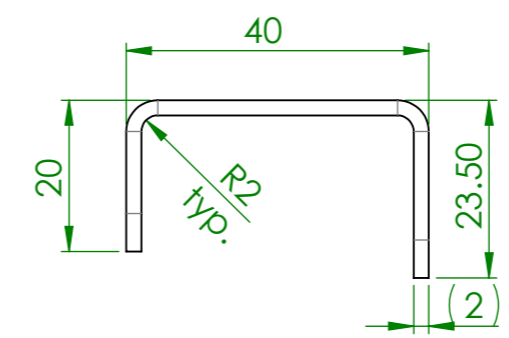
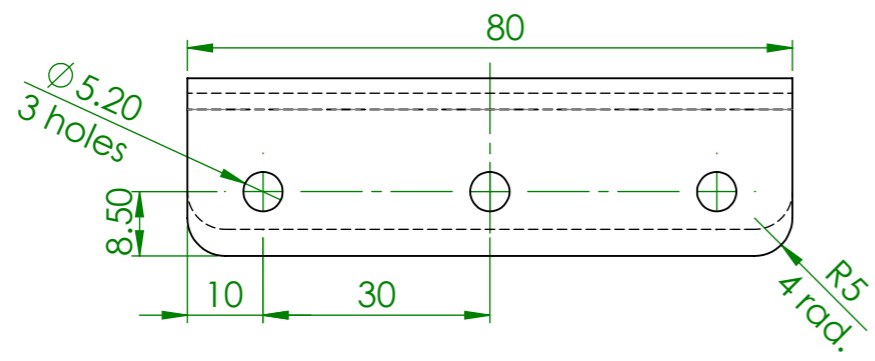

t=2mm; Menge: 4xStück

Verwendungsbereich 80x40x23,5	Toleranz nach DIN ISO 2768-mK	Oberflächen DIN ISO 1302	Maßstab: 1:1	Gewicht: 0.10 Kg
			Werkstoff 1.4301 (X5CrNi18-10)	
Name	Datum		Etagere Grill	
Bearb. M.B.	20/06/2019			
HEIDEBRENNER			ZCxx Gitter ZCxx- 113 U-profile	
				A3