

Verwendungsbereich 1685x750x350	Toleranz nach DIN ISO 2768-mK	Oberflächen DIN ISO 1302	Maßstab: 1:10	Gewicht: 145 kg
			Werkstoff 1.4301 AISI 304	
Name	Datum	Elektro Lava/Wasser Grill STROKKUR		
Bearb. G.N.	07.07.2020			
HEIDEBRENNER		EFD_E - Tischgerät		A3

Art. Nr	HZ	P[kW]	Wasser	Abwasser	Strom
EFDCE	3	3 x 7,5	G 1/2"	DN 50	CEE 63 A, 400V~ 3L+N+PE, 6h
EFDEE	5	5 x 4,5			

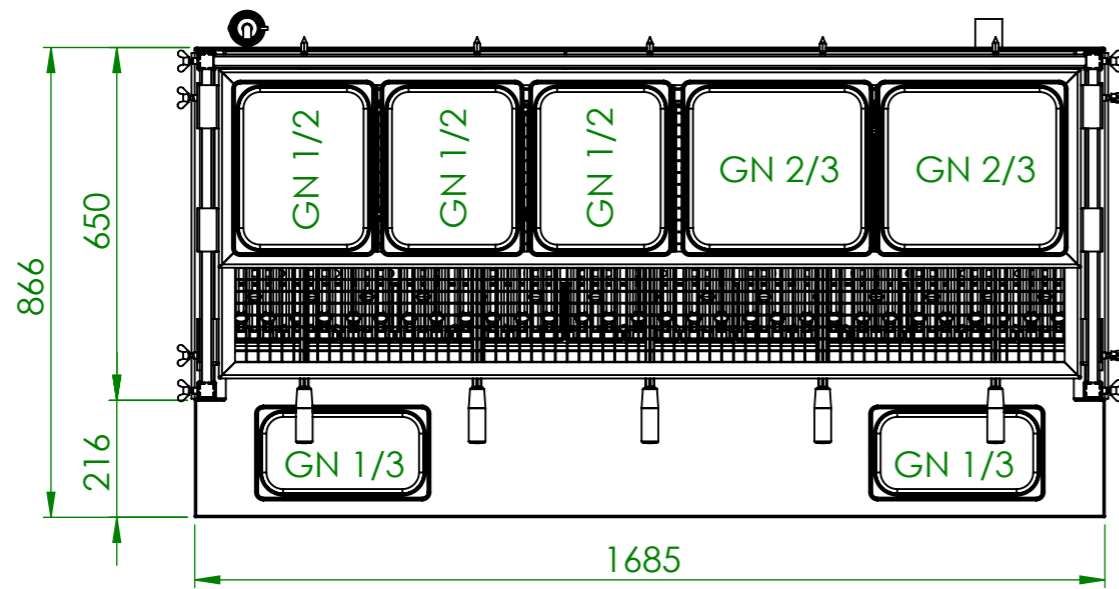

- ZQDQ - 325 GN Halter
- ZQTQ - 1/1 Gitterrost
- ZQSQ - Etagere
- ZMQQ - Spiesshalter
- Spieß
- ZQXQ - GN Halter

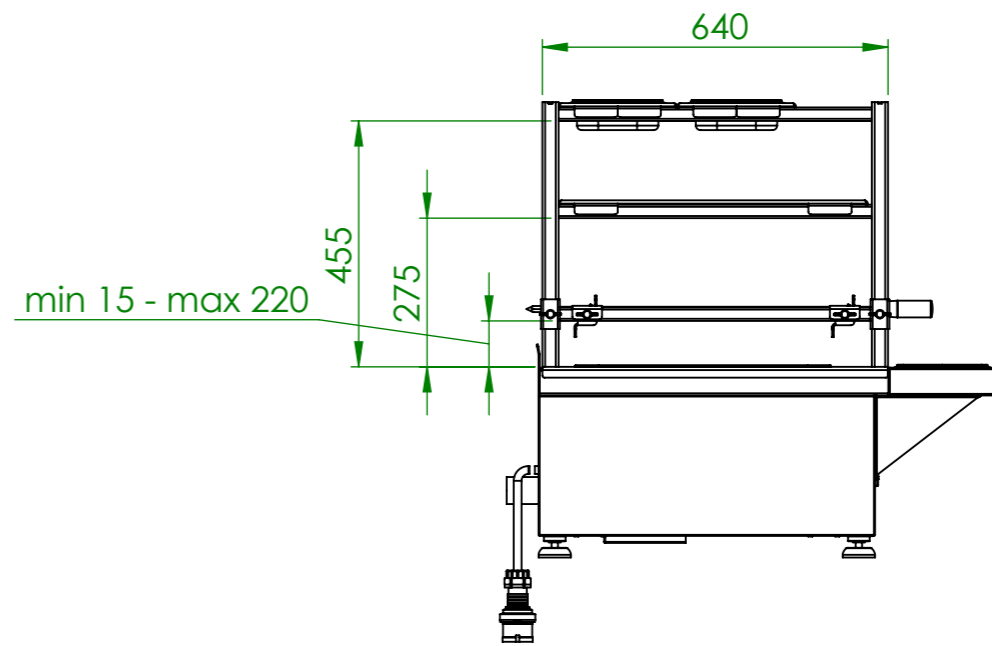
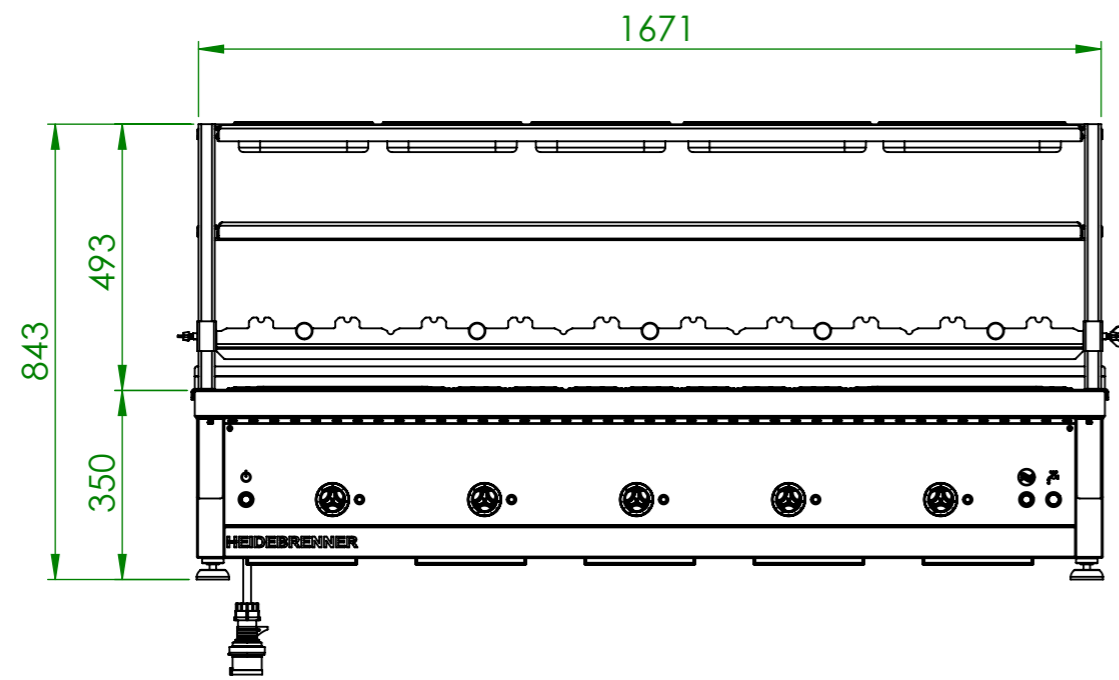
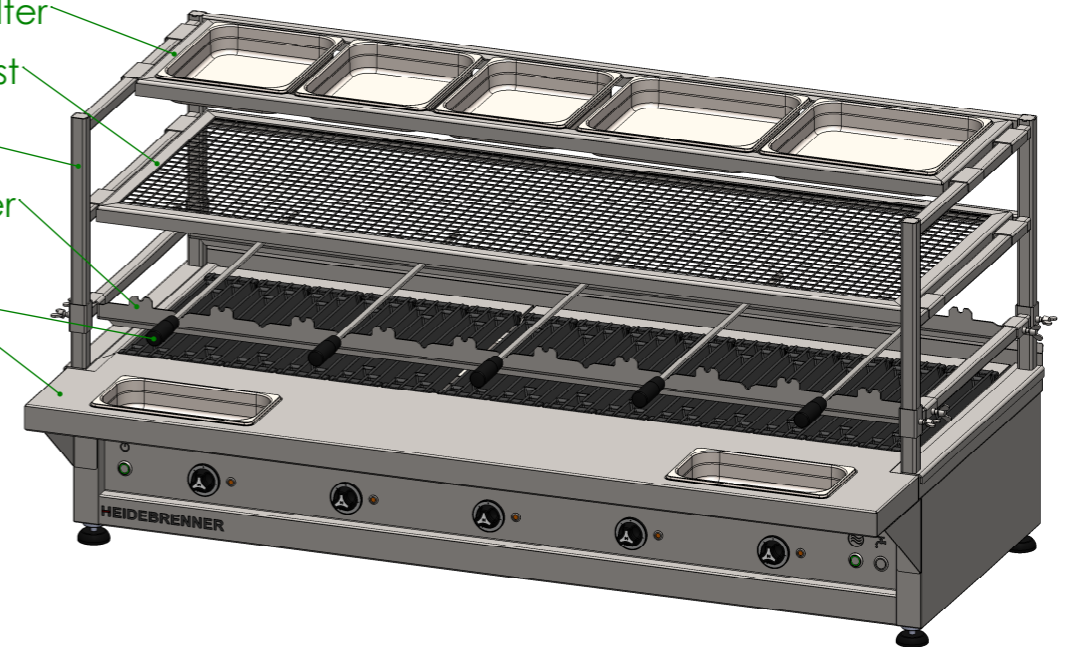

Verwendungsbereich 1685x750x350	Toleranz nach DIN ISO 2768-mK	Oberflächen DIN ISO 1302	Maßstab: 1:14	Gewicht: 220 kg
			Werkstoff 1.4301 AISI 304	
Name	Datum	Elektro Lava/Wasser Grill STROKKUR		
Bearb. G.N.	01.04.2020			
HEIDEBRENNER		EFD_E + ETAGERE		A3