

Verwendungsbereich 1400x650x1000	Toleranz nach DIN ISO 2768-mK	Oberflächen DIN ISO 1302	Maßstab: 1:16	Gewicht: 285.24 kg
			Werkstoff 1.4301	
Name	Datum		Gas Lavastein-Grill LIPARI	
Bearb. M.B.	15.07.2020			
HEIDEBRENNER		GMEE		A3

Artikel Nr.	P [kW]	Pges [kW]	Volumenstrom V [m3/h]	Gasanschluß [Zoll]	Länge Verbrauchsleitung [m] delta p=0.6mBar
GMEE	5x9.3	46.5	4.93	1"	6

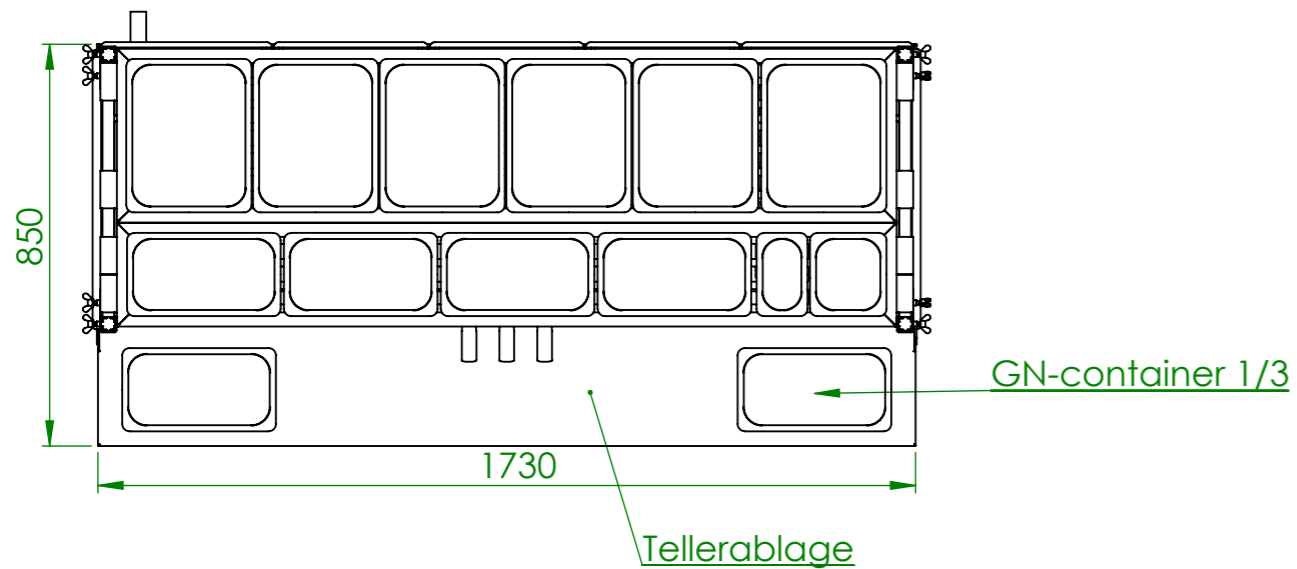
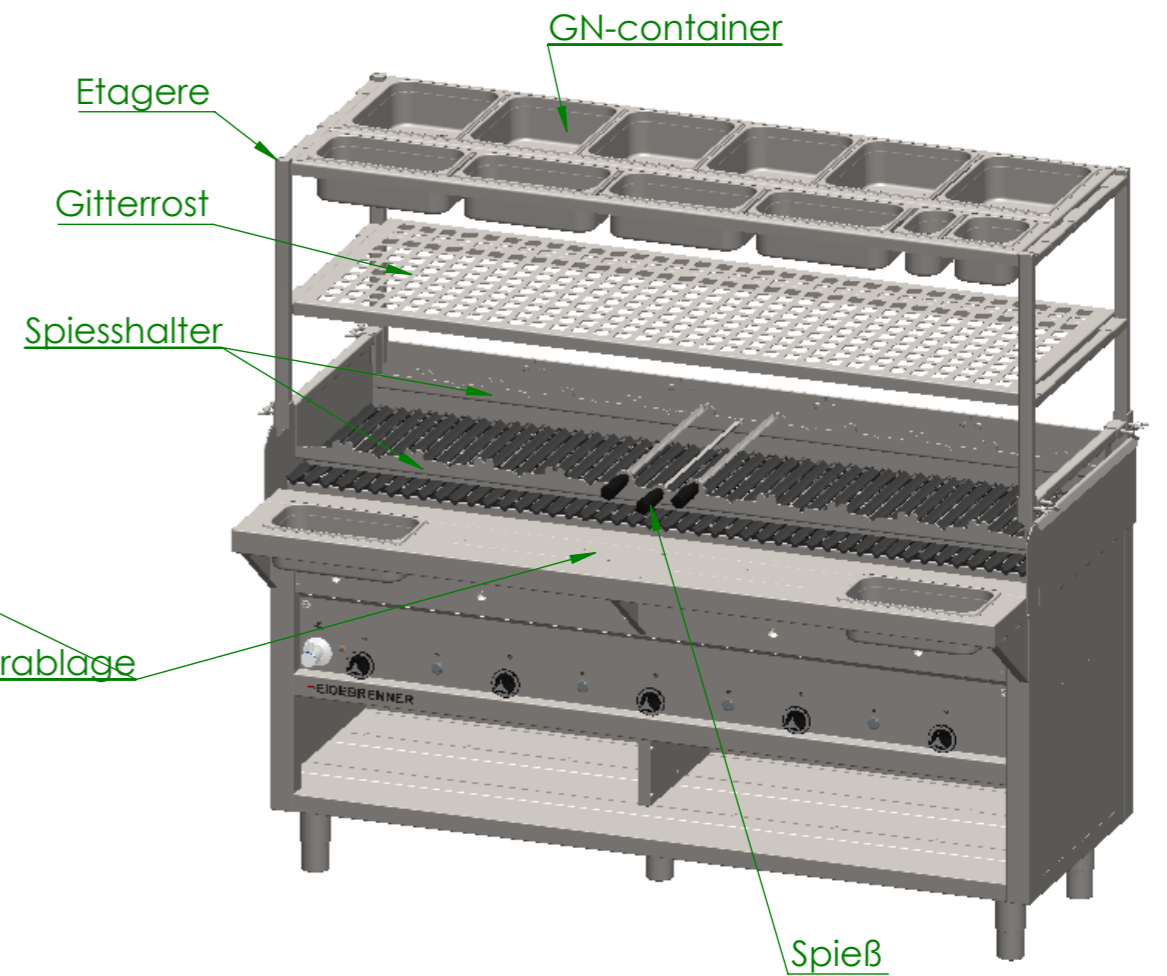
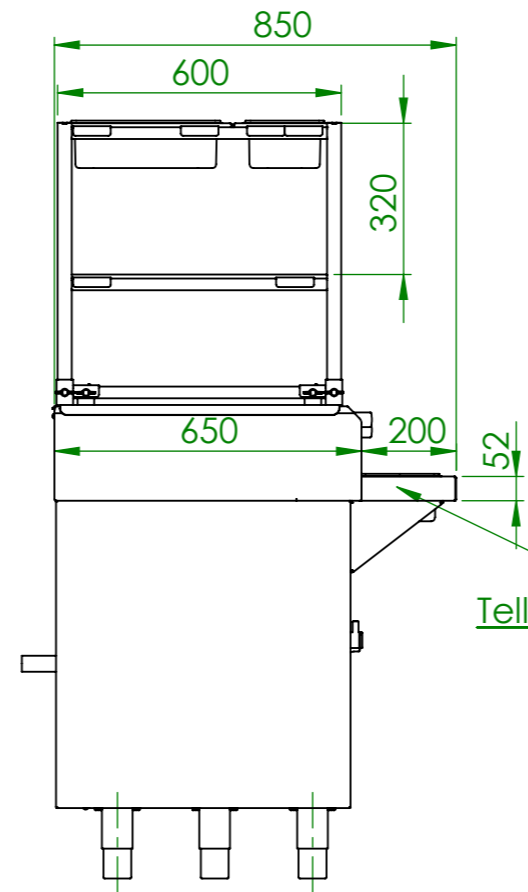
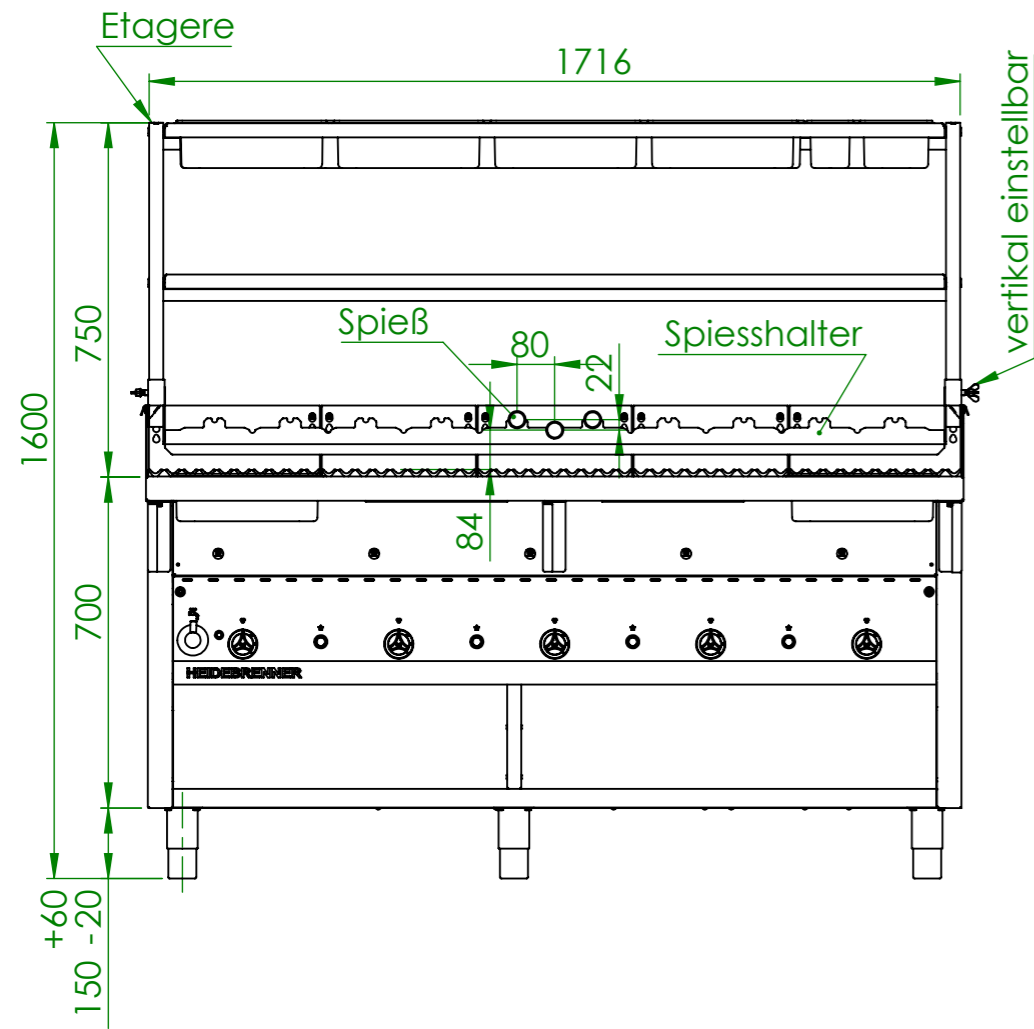

Verwendungsbereich 1730x850x1600	Toleranz nach DIN ISO 2768-mK	Oberflächen DIN ISO 1302	Maßstab: 1:16 Werkstoff 1.4301 AISI 304	Gewicht: 346 kg
Name	Datum	Gas Lavastein-Grill LIPARI		
Bearb. M.B.	15.07.2020			
HEIDEBRENNER		GMEE+Etagere+GN keeper		A3