

Artikel Nr.	H [mm]	B [mm]	T [mm]	Grillfläche	Steuerung	HZ	P [kW]	Pges [kW]	Sicherung	Auslösecharakteristik	Anschlußstecker
EBIHD	250	1430	750	Glatt	Elektronisch	2	2x9	18	3 x 10A	Typ B	CEE 32 A, 400V~ 3L+N+PE, 6h
EBIJD						4	4x4,5				
EIIHD						2	2x9				
EIIJD						4	4x4,5				
EBIBD				Glatt	Analog	2	2x9	18			
EBIDD						4	4x4,5				
EIIBD						2	2x9				
EIIDD						4	4x4,5				
				Geriffelt							

Verwendungsbereich 1430x750x250	Toleranz nach DIN ISO 2768-mK	Oberflächen DIN ISO 1302	Maßstab: 1:10 Werkstoff AISI 304	Gewicht: 193 Kg
Name	Datum	Elektro Bratplatte "HOKKAIDO"		
Bearb. G.N.	05.05.2020			
HEIDEBRENNER		E_I_D - Einbaugerät		A3

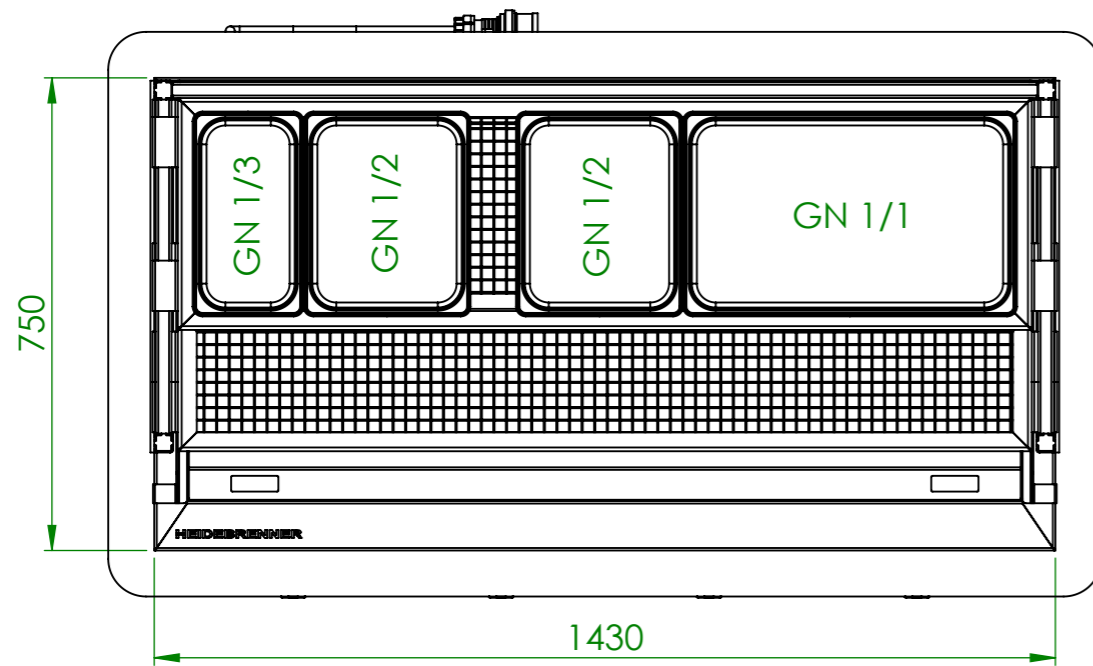

- ZBDP
Auflage für 1/3 GN
- ZBSP
Etagere
- ZBUP
Auflage mit 2/3 Gitterrost
- ZBVP
Auflage mit 1/3 Gitterrost

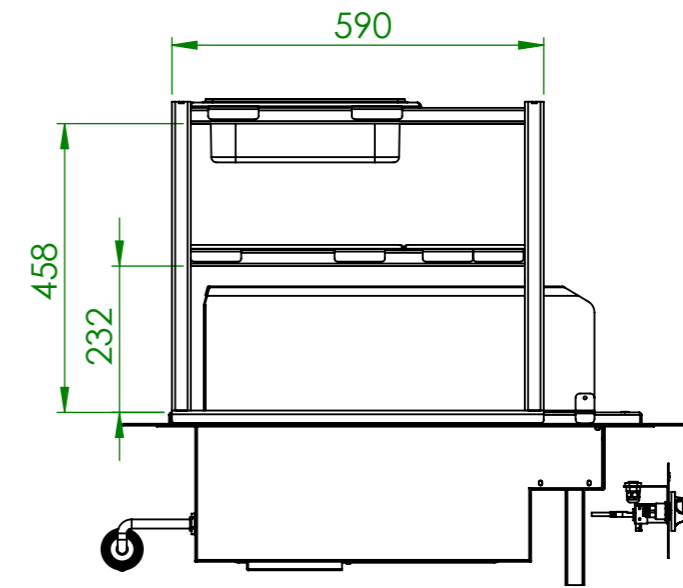
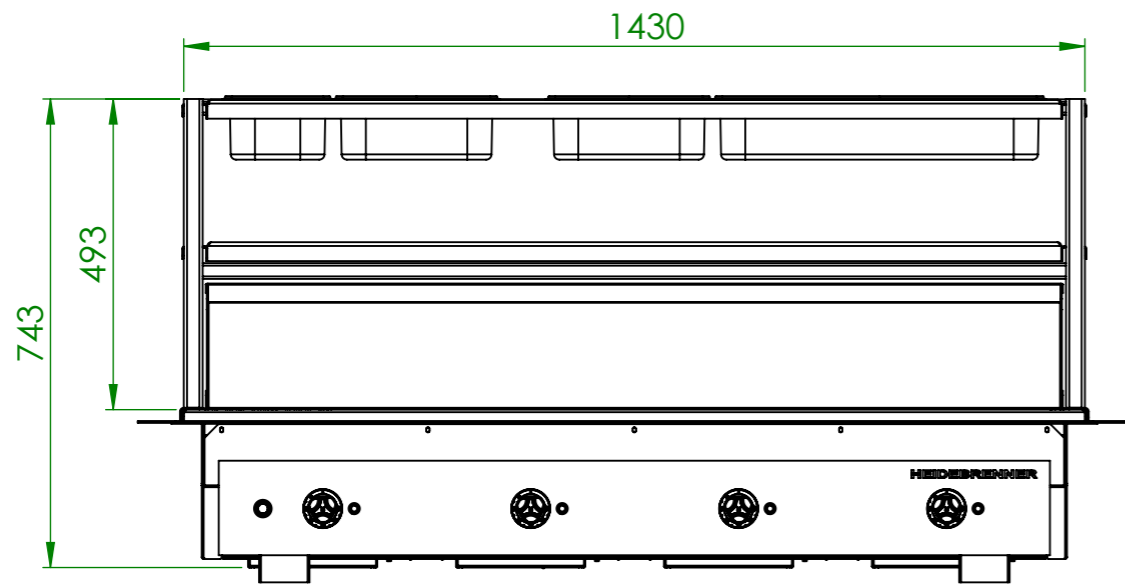
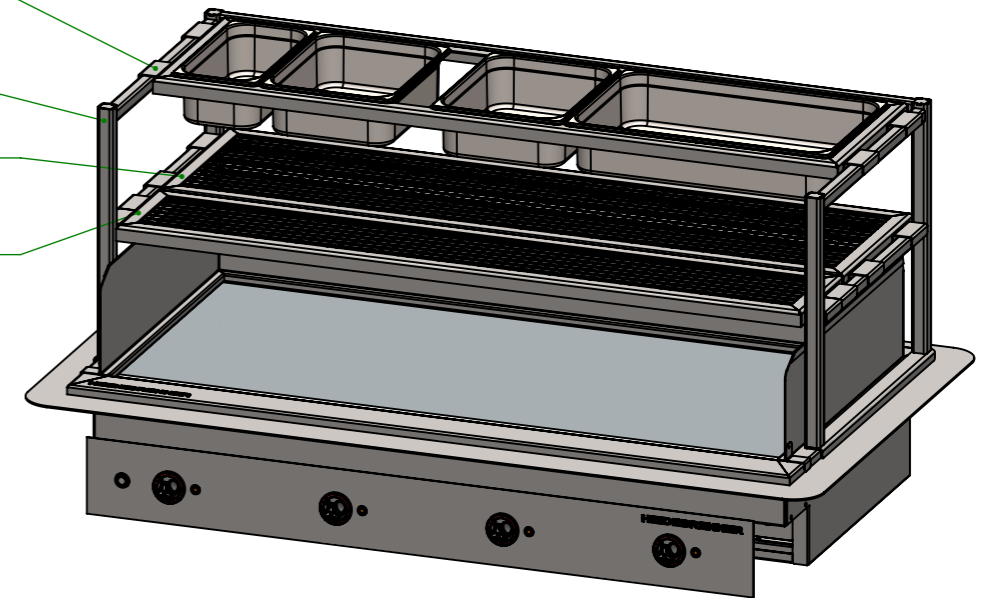

Verwendungsbereich 1430x750x743	Toleranz nach DIN ISO 2768-mK	Oberflächen DIN ISO 1302	Maßstab: 1:12	Gewicht: 228 Kg
			Werkstoff AISI 304	
Name	Datum	Elektro Bratplatte "HOKKAIDO"		
Bearb. G.N.	11.05.2020			
HEIDEBRENNER		E_I_D - Einbaugerät		A3

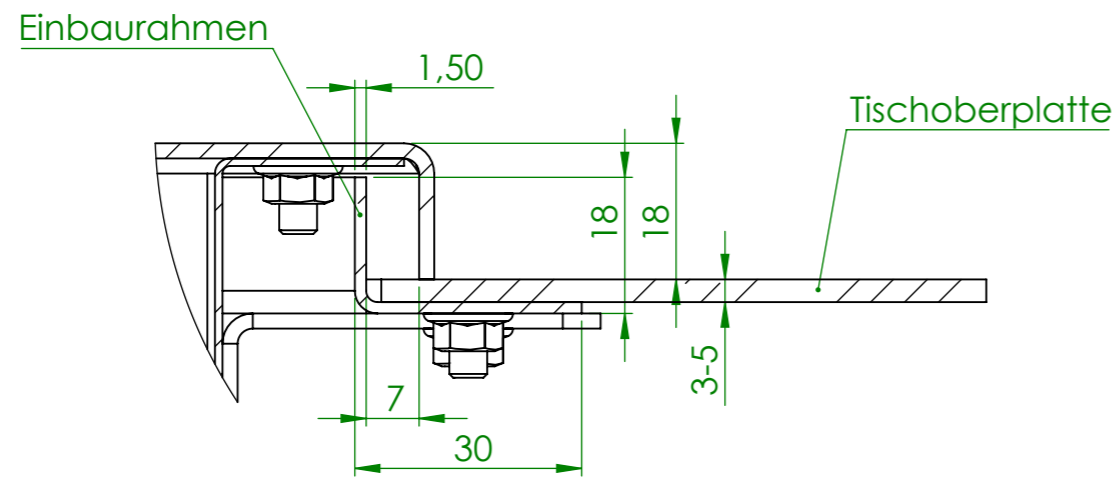

D (1 : 1)

AUSSCHNITTMASS

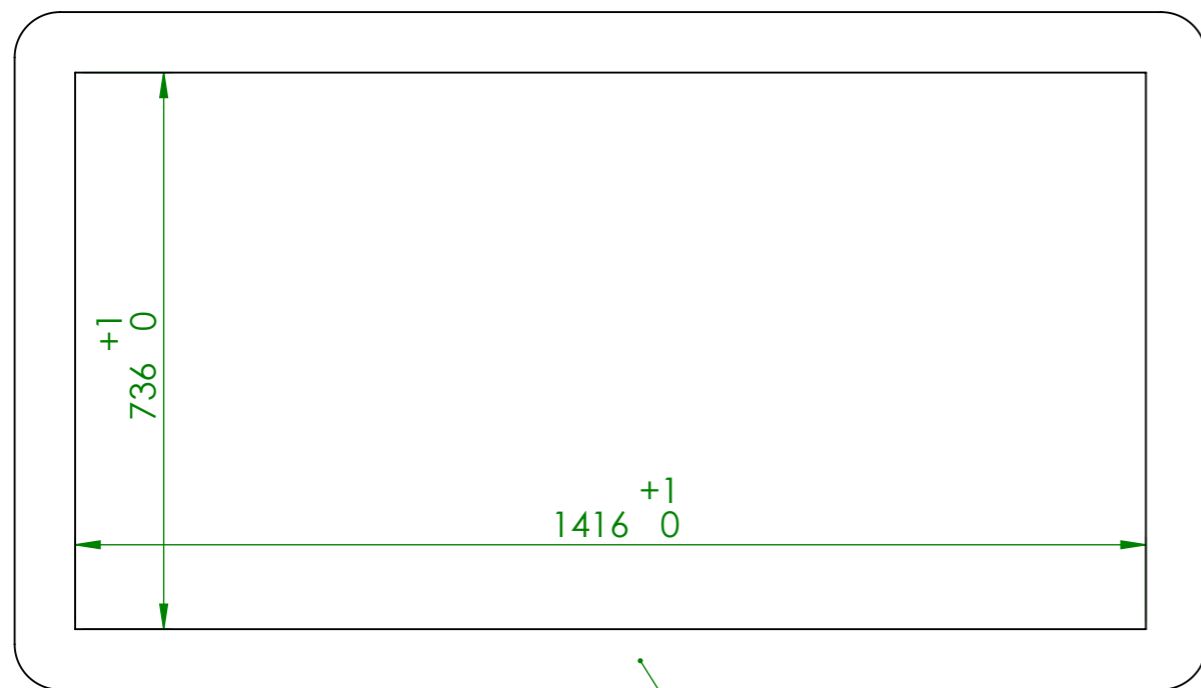

Tischoberplatte

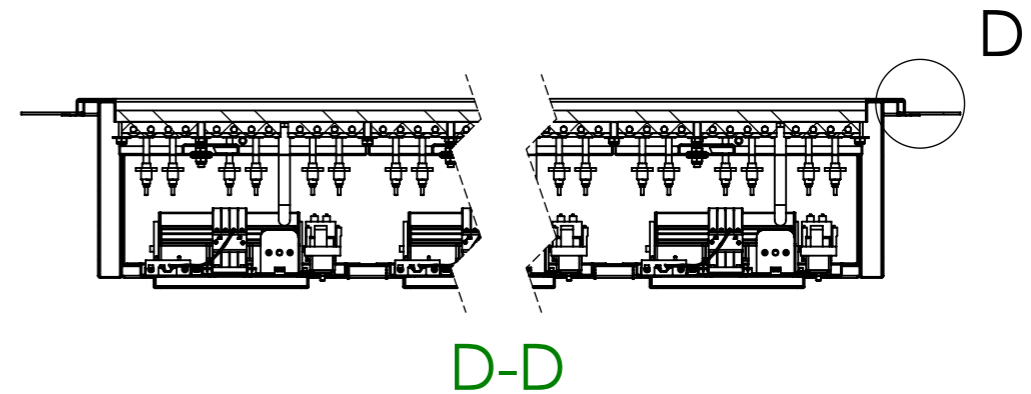

D-D

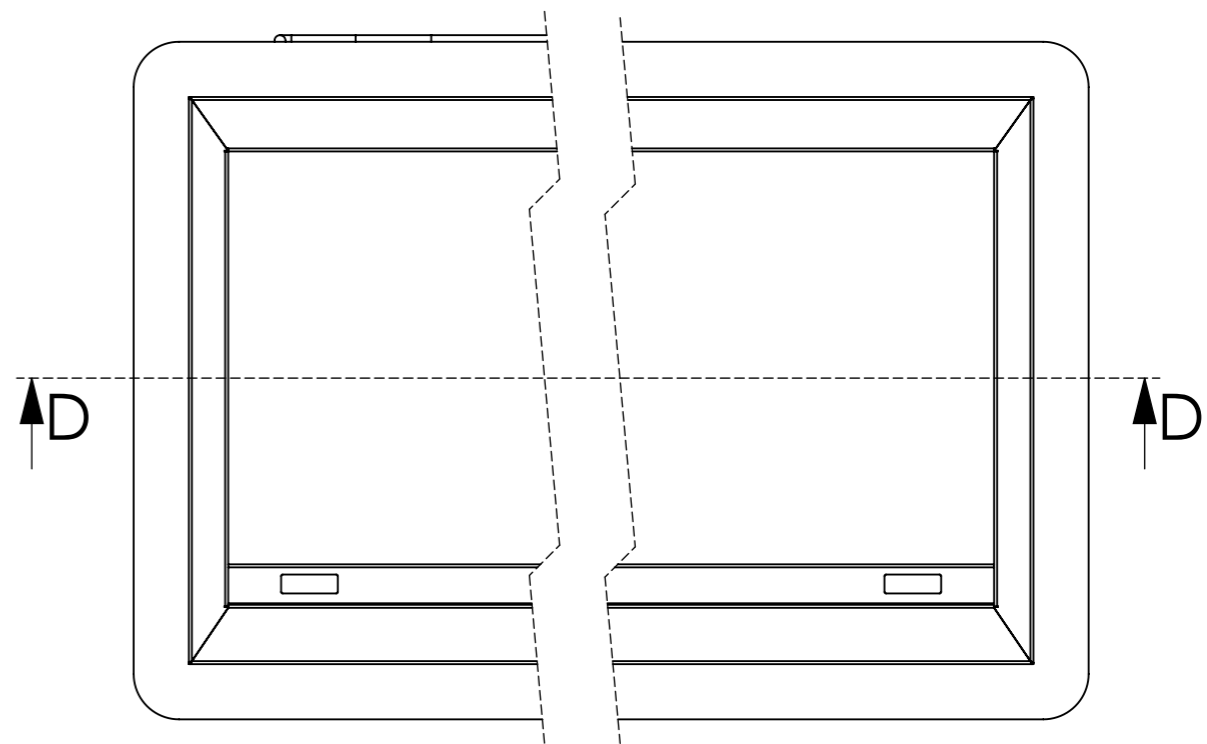

Gerät

Verwendungsbereich 1430x750x250	Toleranz nach DIN ISO 2768-mK	Oberflächen DIN ISO 1302	Maßstab: 1:10 Gewicht: 193 Kg
		Werkstoff AISI 304	
Name	Datum	Elektro Bratplatte "HOKKAIDO"	
Bearb. G.N.	24.04.2020		
HEIDEBRENNER		E_I_D - Einbaugerät	A3