

| Artikel Nr. | P [kW] | Pges [kW] | Volumenstrom V [m3/h] | Gasanschluß [Zoll] | Länge Verbrauchsleitung [m] delta p=0.6mBar |
|-------------|--------|-----------|-----------------------|--------------------|--|
| GNKC | 3x12,8 | 38,4 | 4,07 | 3/4" | 6 |

| | | | | |
|-------------------------------------|----------------------------------|------------------------------|-----------------------------------|-----------------|
| Verwendungsbereich 1070x900x1000 | Toleranz nach DIN ISO 2768-mK | Oberflächen DIN ISO 1302 | Maßstab: 1:16 Werkstoff 1.4301 | Gewicht: 227 kg |
| Name | Datum | Gas Wassergrill PLANO | | |
| Bearb. M.B. | 14.07.2020 | | | |
| HEIDEBRENNER | | GNKC | | A3 |

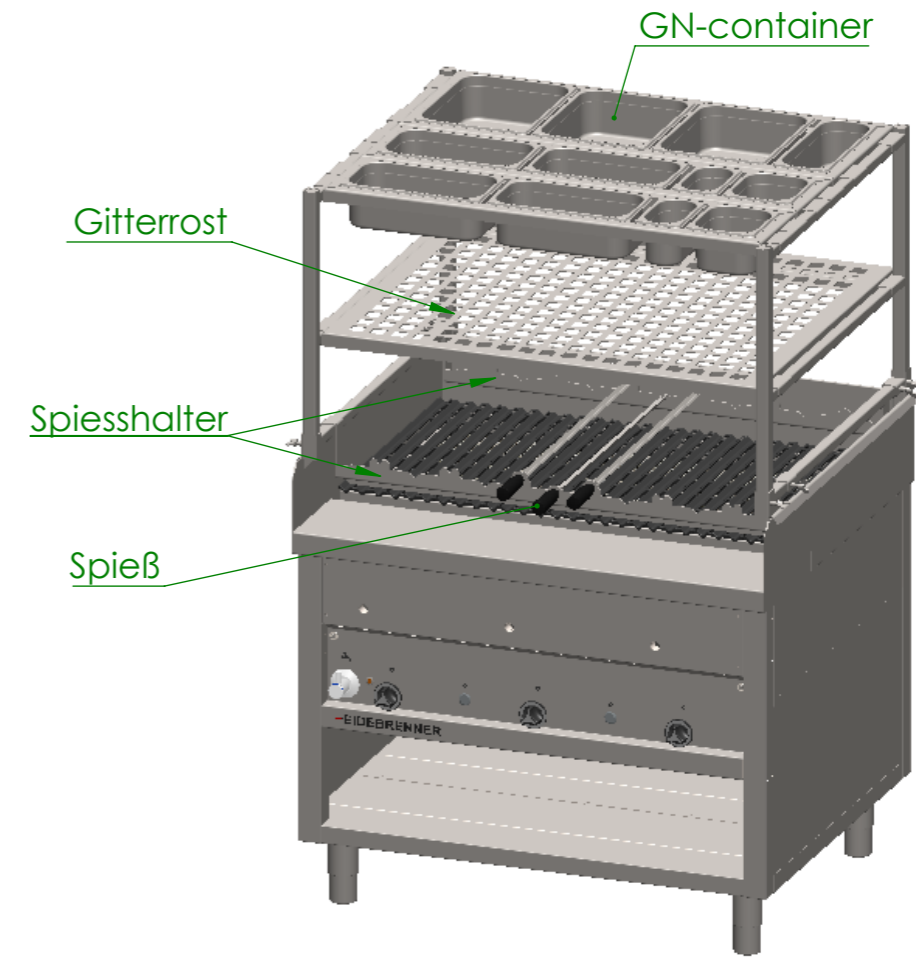
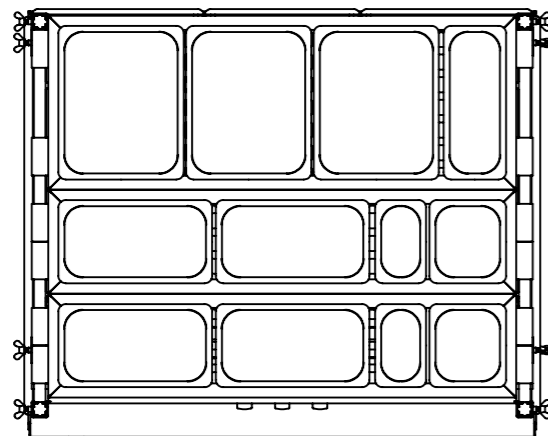
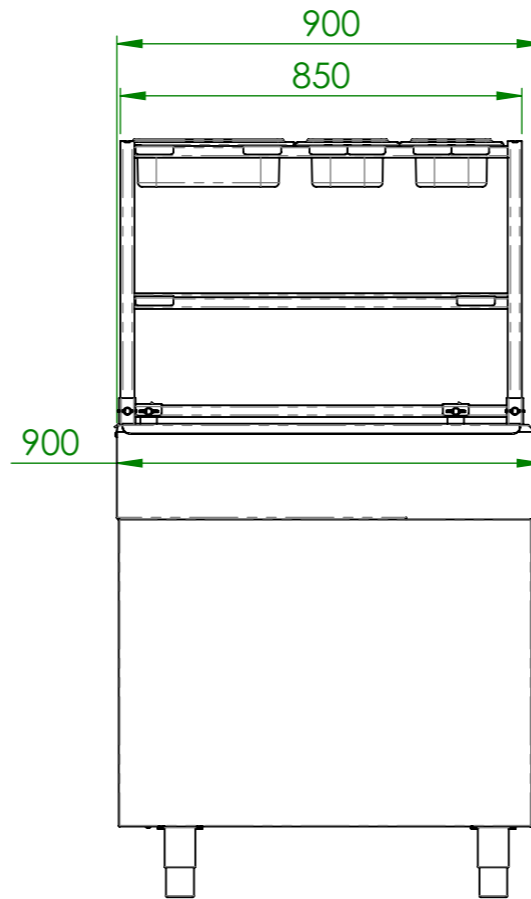
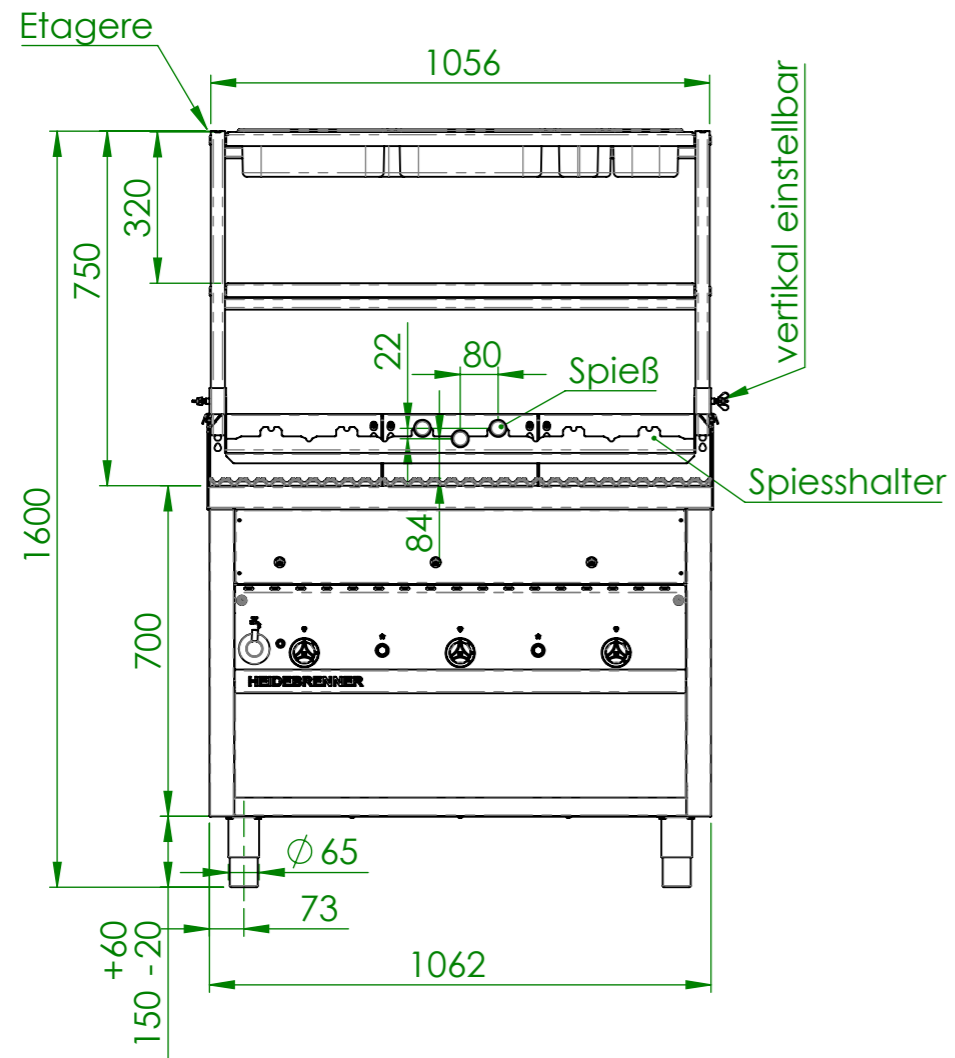

| | | | | |
|-------------------------------------|----------------------------------|------------------------------|---------------------|--------------------|
| Verwendungsbereich 1070x900x1600 | Toleranz nach DIN ISO 2768-mK | Oberflächen DIN ISO 1302 | Maßstab: 1:16 | Gewicht: 273 kg |
| | | | Werkstoff 1.4301 | |
| Name | Datum | Gas Wassergrill PLANO | | |
| Bearb. M.B. | 14.07.2020 | | | |
| HEIDEBRENNER | | GNKC | | A3 |