

Verwendungsbereich 410x650x590	Toleranz nach DIN ISO 2768-mK	Oberflächen DIN ISO 1302	Maßstab: 1:8	Gewicht: 65.84 kg
			Werkstoff 1.4301	
Name	Datum	Gas Lavastein Grill FILICUDI		
Bearb. M.B.	15.07.2020			
HEIDEBRENNER		GMDA		A3

Artikel Nr.	P [kW]	Pges [kW]	Volumenstrom V [m3/h]	Gasanschluß [Zoll]	Länge Verbrauchsleitung [m] delta p=0.6mBar
GMDA	1x9,3	9,3	0.98	1/2"	6

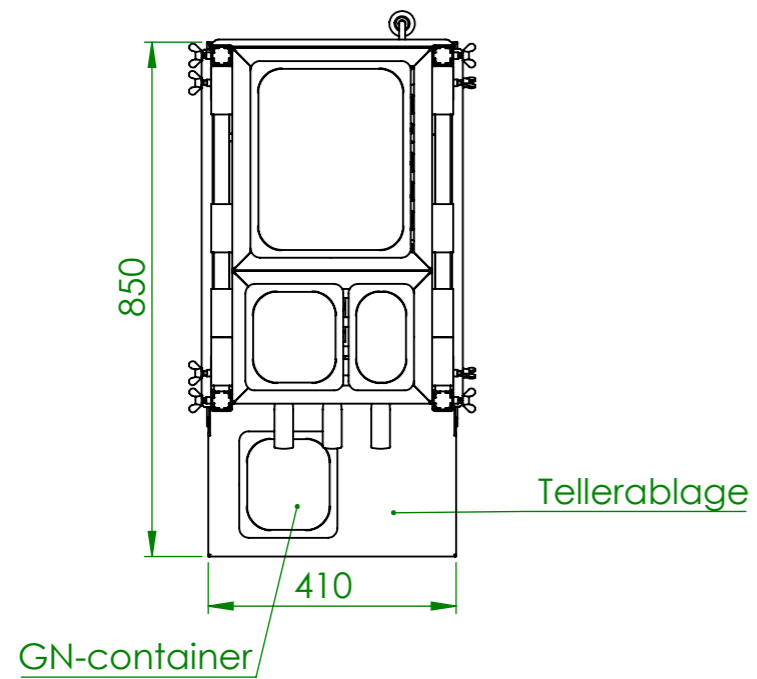
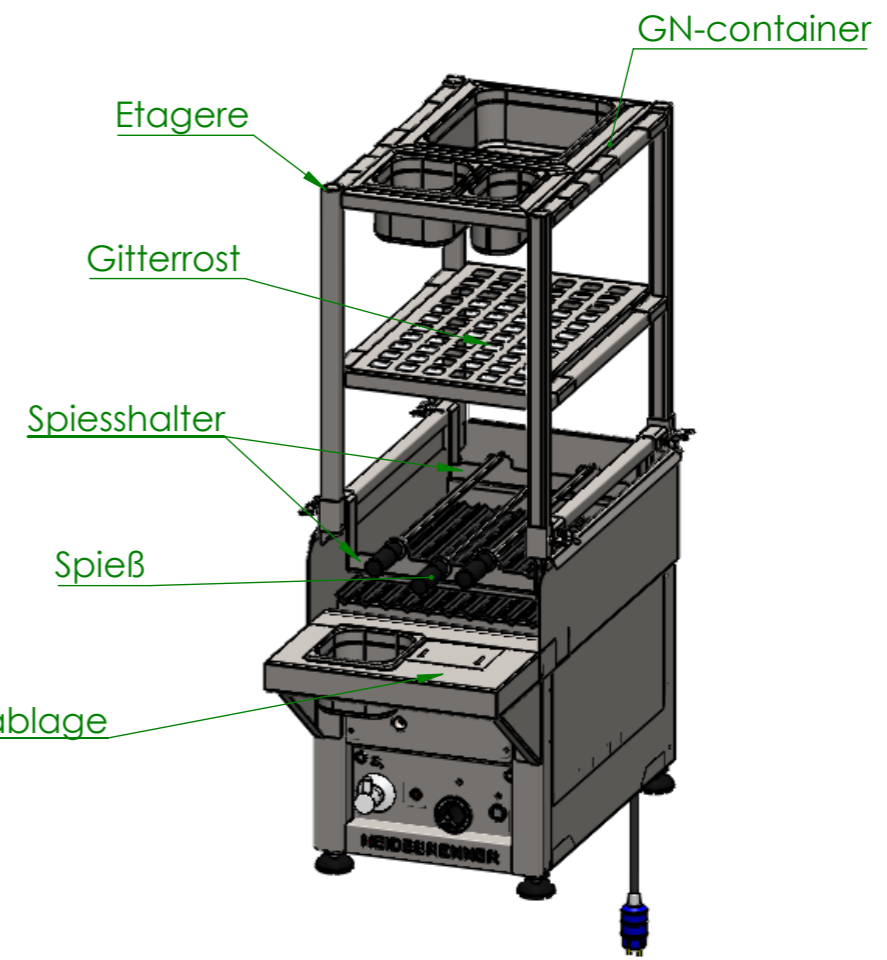
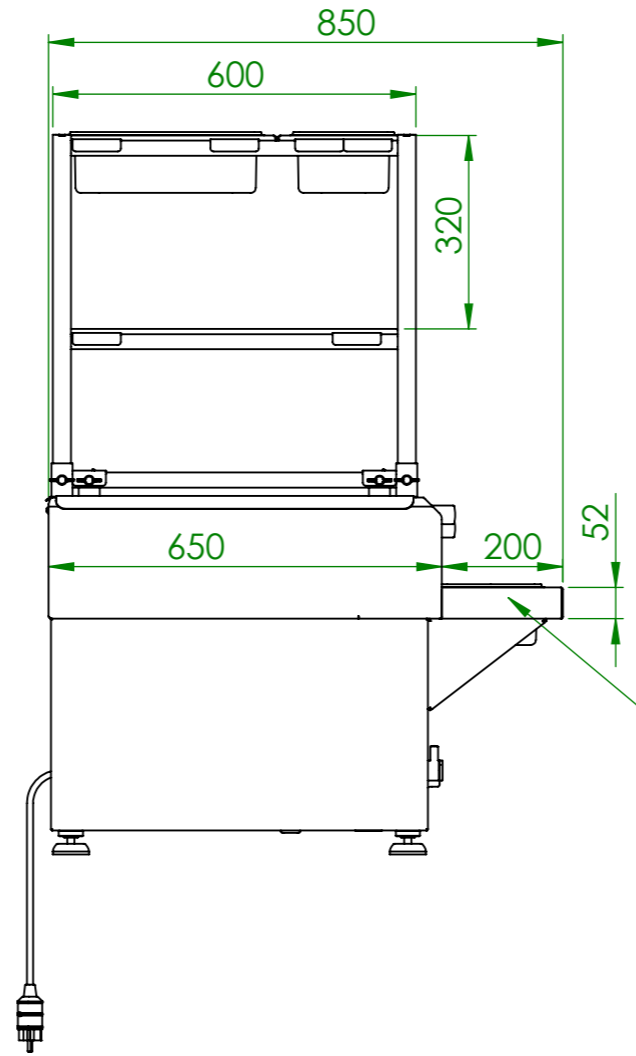
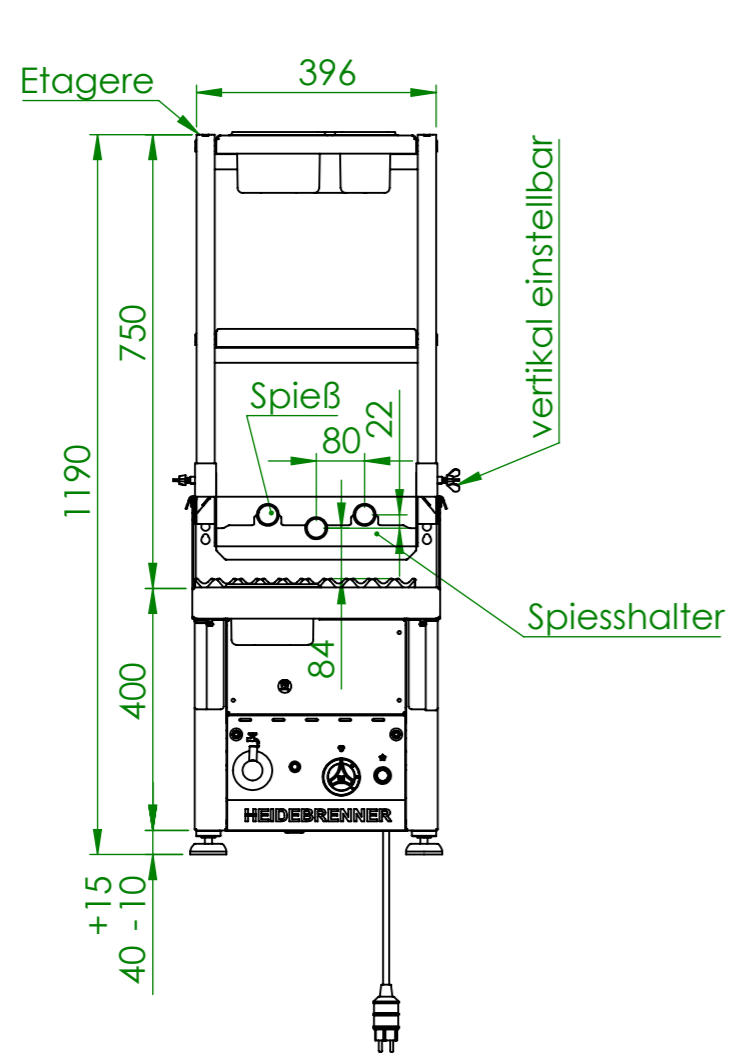

Verwendungsbereich 410x850x1190	Toleranz nach DIN ISO 2768-mK	Oberflächen DIN ISO 1302	Maßstab: 1:12.5	Gewicht: 92 kg
			Werkstoff 1.4301 AISI 304	
Name	Datum	Gas Lavastein-Grill FILICUDI		
Bearb. M.B.	15.07.2020			
HEIDEBRENNER		GMDA		A3