

Art.Nr	KochStellen-Brenner	WarzenBrenner	P[kW]	Pges [kW]	Volumenstrom V[m3/h]	Gasanschluß [Zoll]	Länge Verbrauchsleitung [m] delta p=0.6mBar
GLAED	5	-	5,8	29	3,1	3/4	10
GLALD	-	5	8,7	43,5	4,63	1	15

Verwendungsbereich 2025x600x350	Toleranz nach DIN ISO 2768-mK	Oberflächen DIN ISO 1302	Maßstab: 1:12	Gewicht: 130 kg
Name		Datum		
Bearb. M.G.		17.12.2020		
Werkstoff 1.4301 AISI 304		Gas-Range „NEVADA“		
HEIDEBRENNER		GLA_D		A3

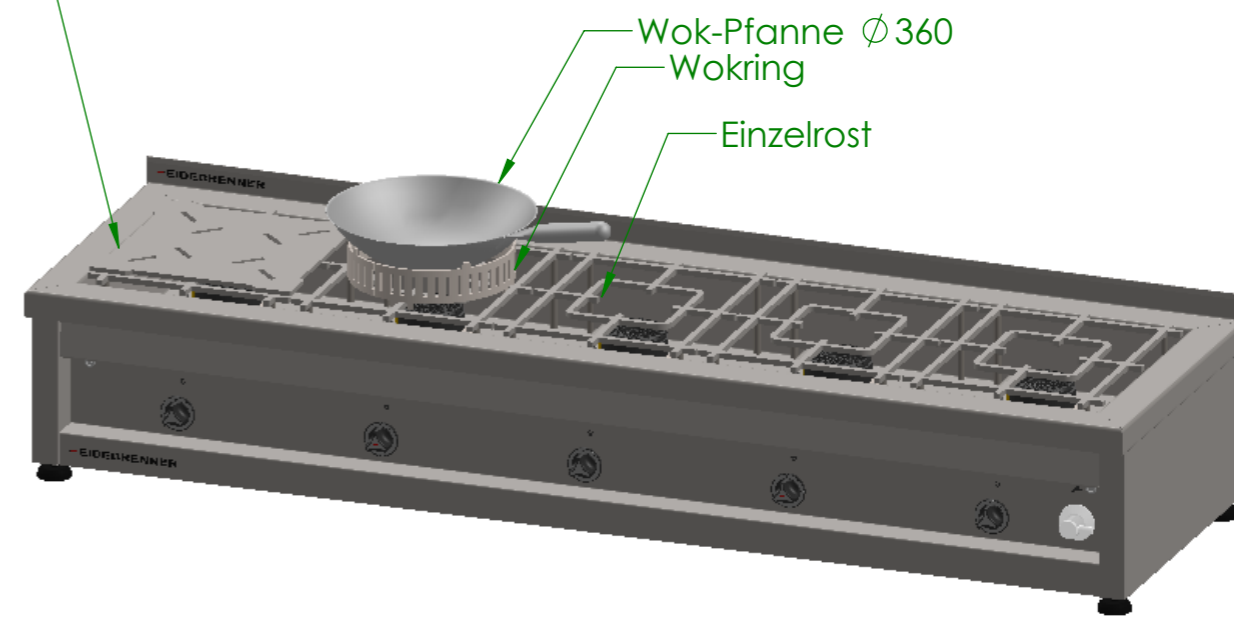
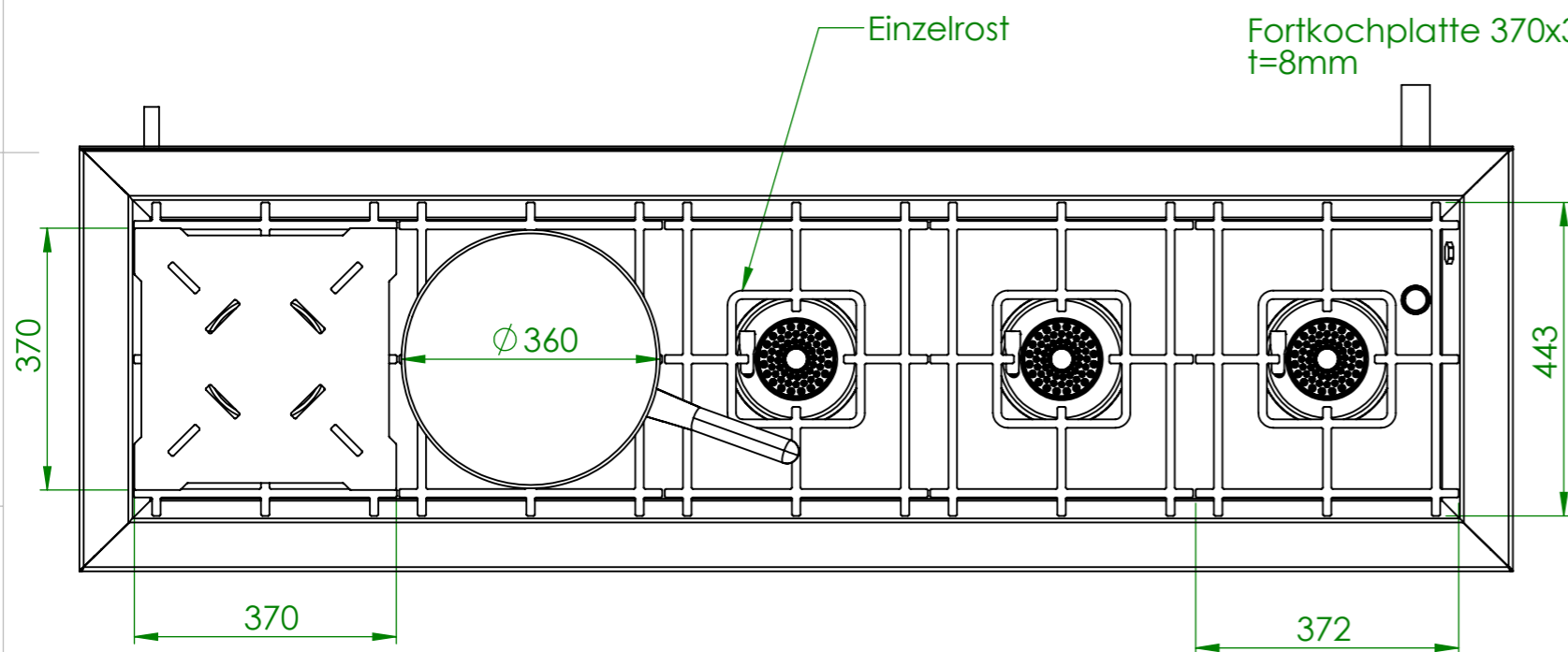
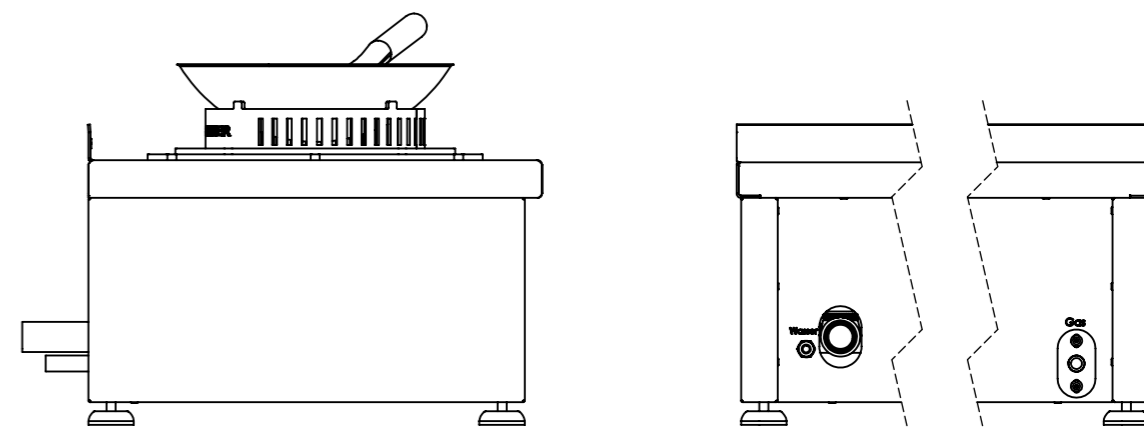
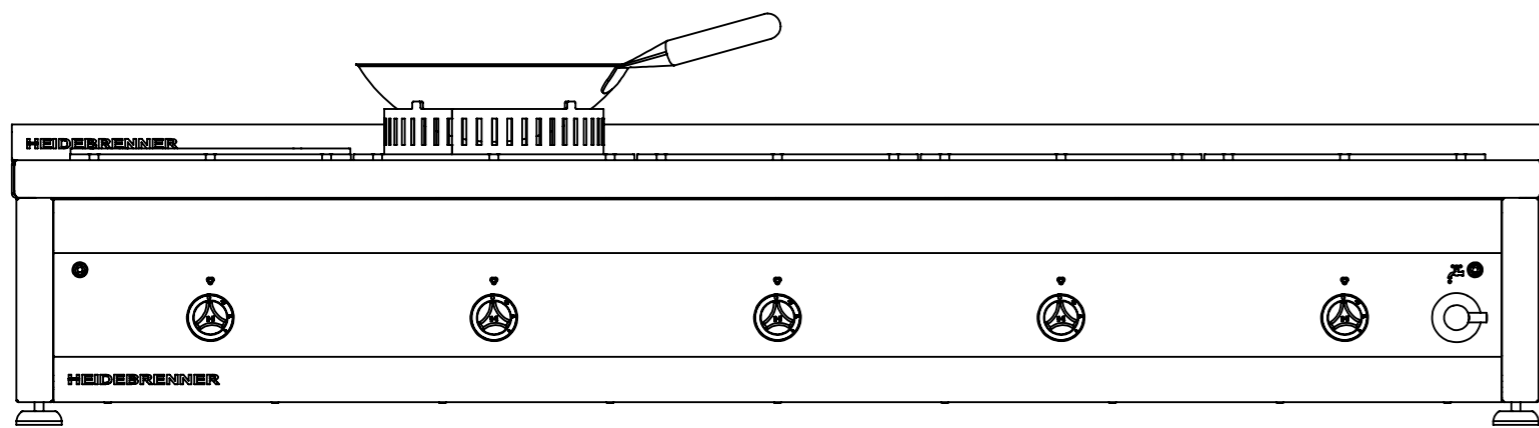

Verwendungsbereich 2025x600x350	Toleranz nach DIN ISO 2768-mK	Oberflächen DIN ISO 1302	Maßstab: 1:10	Gewicht: 144 kg
			Werkstoff 1.4301 AISI 304	
Name	Datum	Gas-Range „NEVADA“		
Bearb. M.G.	17.12.2020			
HEIDEBRENNER		GLA_D + Zubehör		A3