

Schauloch Zündbrenner

Elektrische Zündung

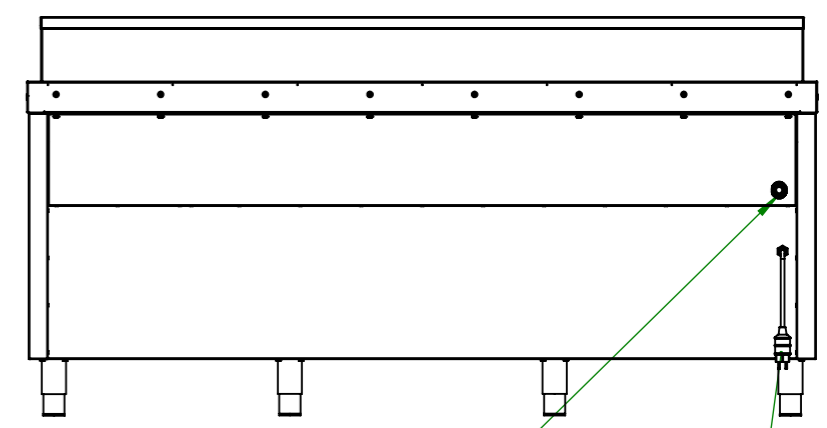
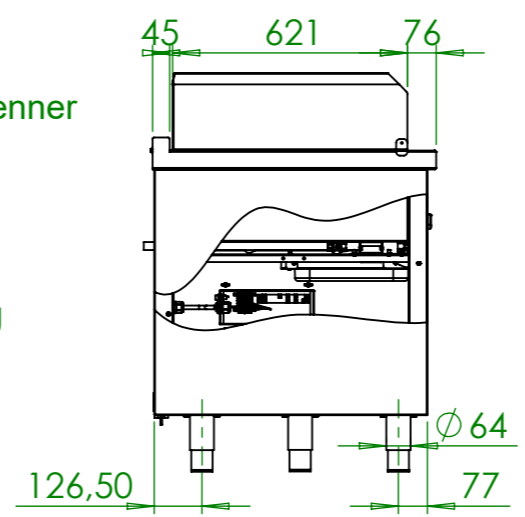

Gasanschluss G3/4"
Stromanschluss
CEE 7/4, 1L+N+PE, P=20W

Umgebungstemperatur $T \leq 30^{\circ}\text{C}$

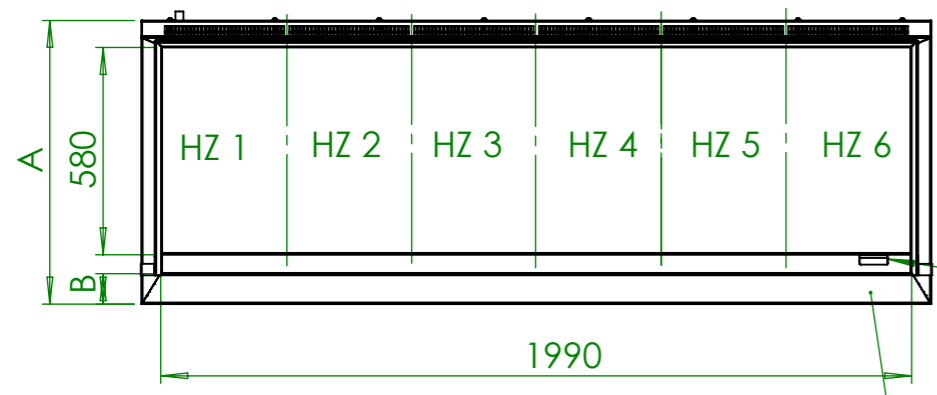

Fettrinne mit Ablauf

Rz 5

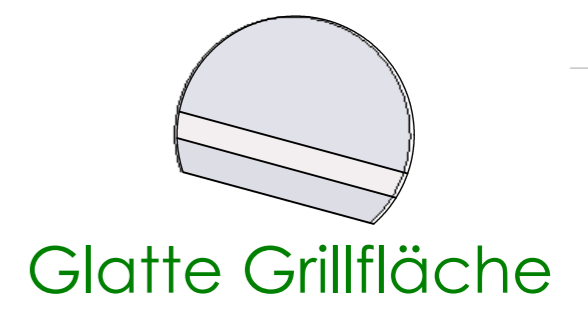
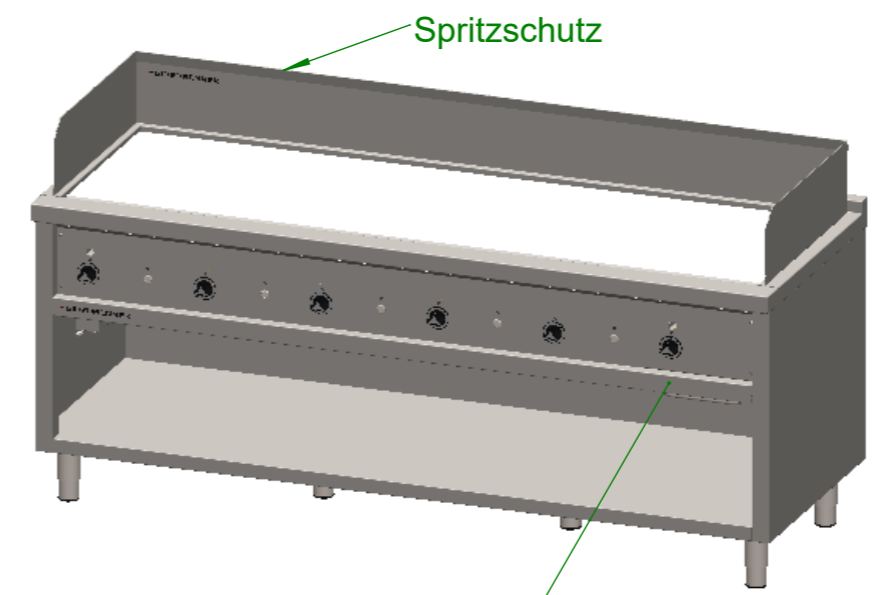

Artikel Nr.	Tiefe A [mm]	Obere breite B [mm]	Grillfläche	HZ	P [kW]	Pges [kW]	Gasanschluß [Zoll]	Länge Verbrauchsleitung [m] delta p=0.6mBar
GBHF	750	80	Glatt	6	5,8	34,8	3/4"	6
GIHF			Geriffelt					
GBKF	900	230	Glatt					
GIKF			Geriffelt					

Verwendungsbereich	Toleranz nach DIN ISO 2768-mK	Oberflächen DIN ISO 1302	Maßstab: 1:20 Werkstoff: 1.4301 AISI 304	Gewicht: kg
Name	Datum		Gas Bratplatte - TANEGA	
Bearb. S.B.	09.10.2020			
HEIDEBRENNER			GBHF GIHF GBKF GIKF	A3

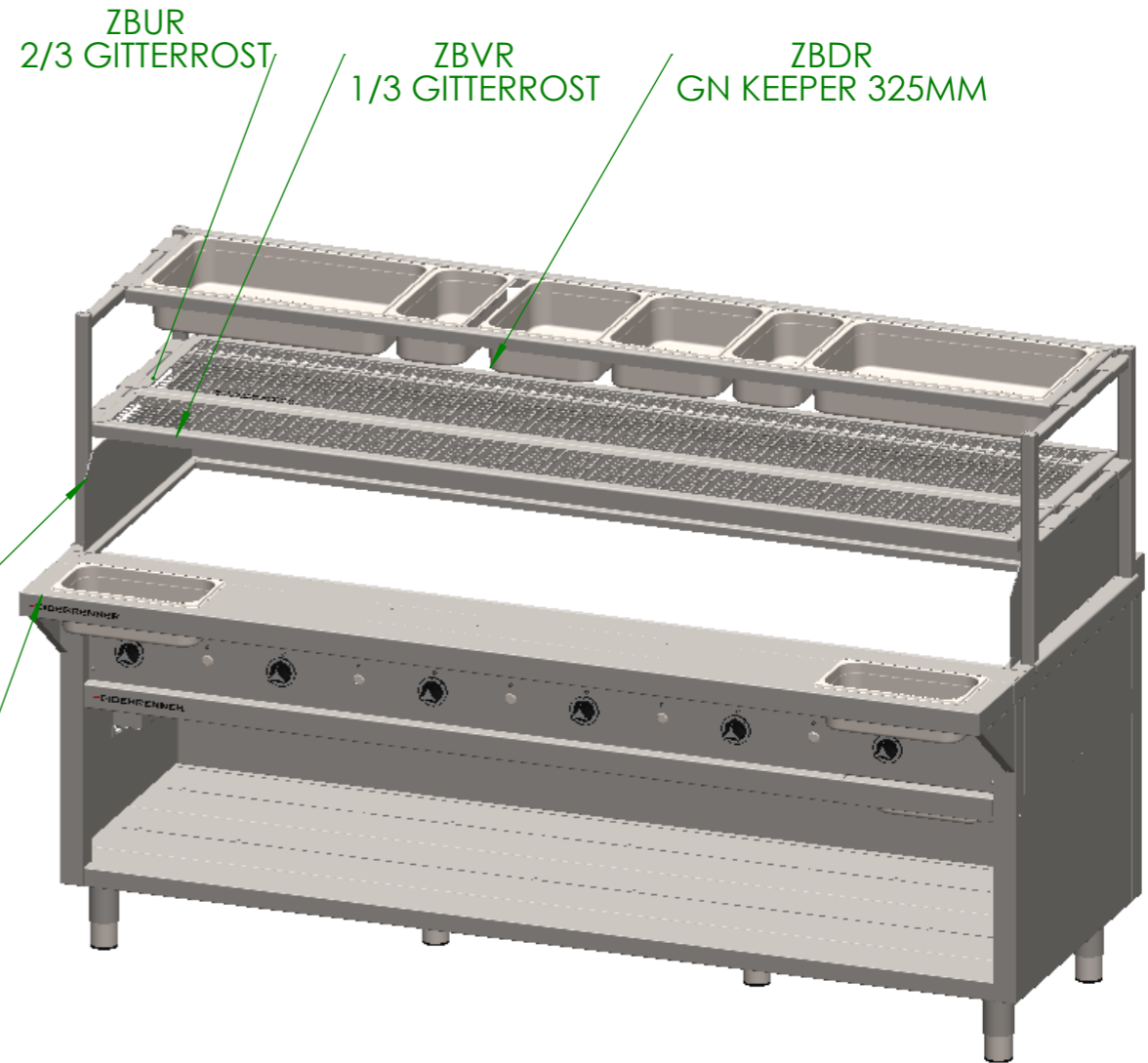
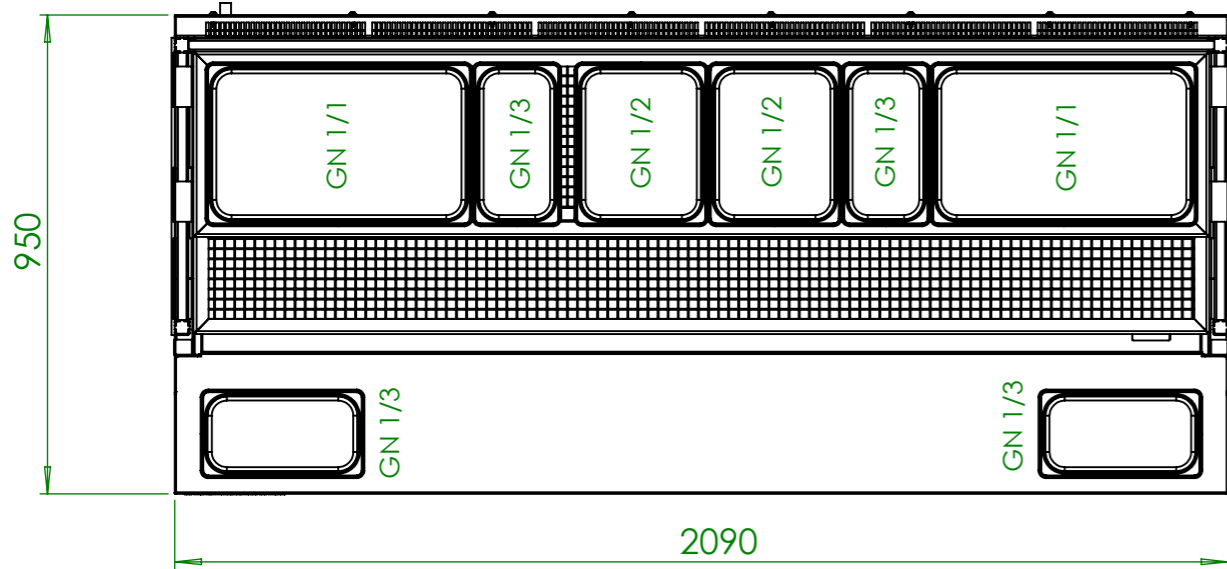
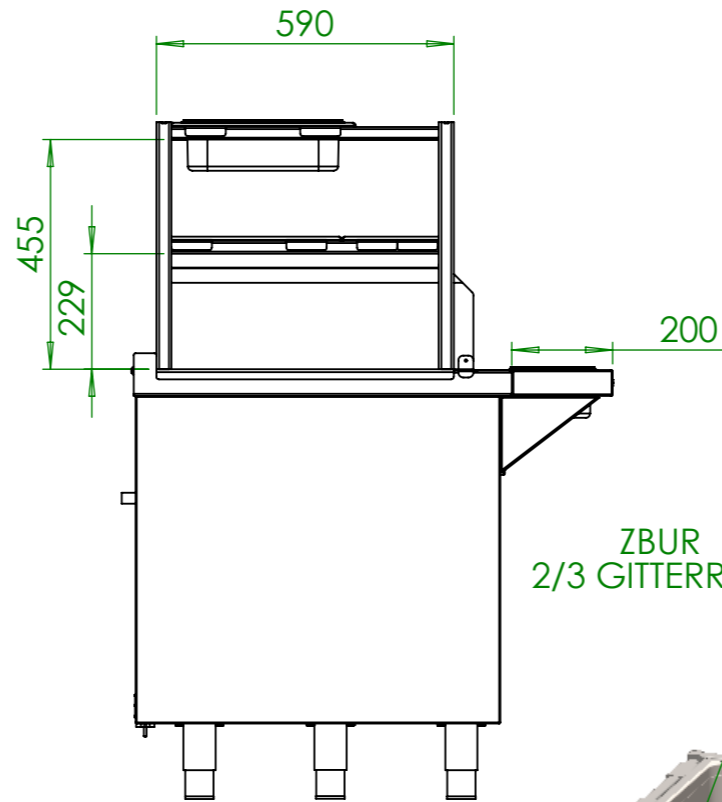
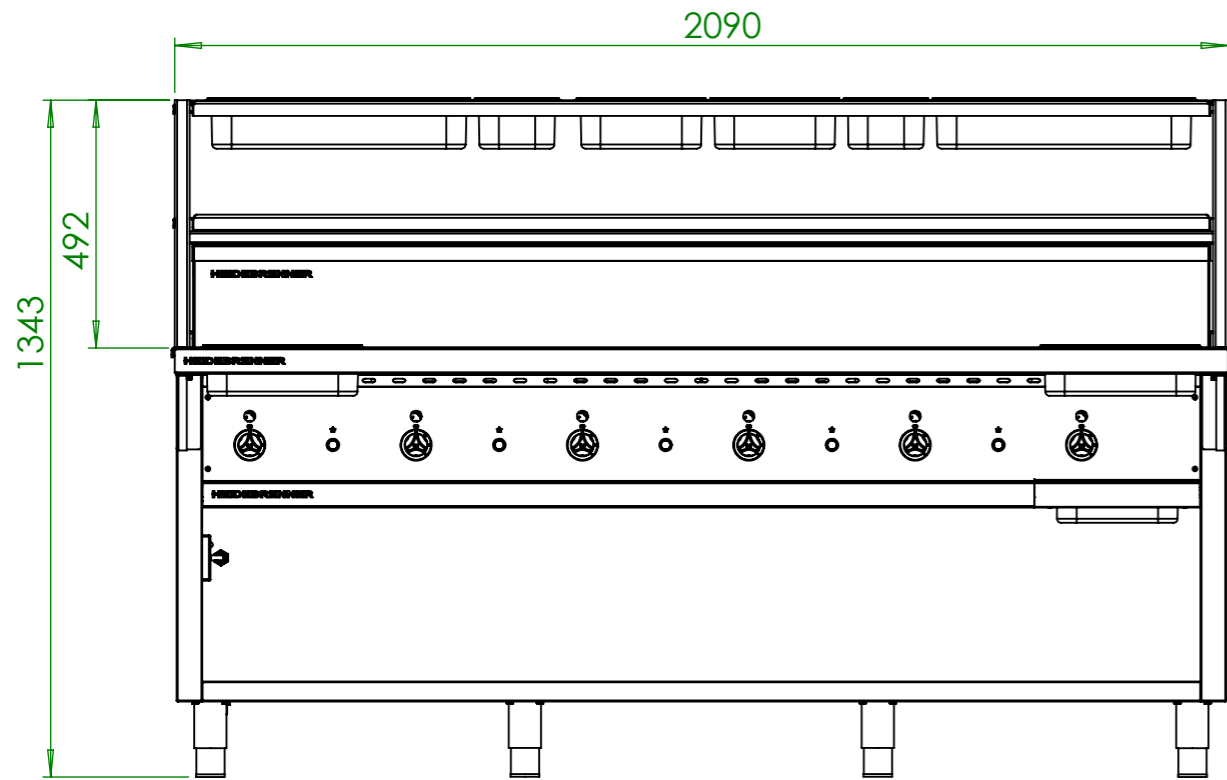

Verwendungsbereich	Toleranz nach DIN ISO 2768-mK	Oberflächen DIN ISO 1302	Maßstab: 1:15	Gewicht: kg
			Werkstoff: 1.4301 AISI 304	
Name	Datum		Gas Bratplatte - TANEGA	
Bearb. S.B.	09.10.2020			
HEIDEBRENNER			GBHF GIHF GBKF GIKF	A3