

Artikel Nr.	H [mm]	B [mm]	T [mm]	Grillfläche	Steuerung	HZ	P [kW]	Pges [kW]	Sicherung	Auslösecharakteristik	Anschlußstecker
EBIGB	250	770	750	Glatt	Elektronisch	1	9	9	3 x 10A	Typ B	CEE 16 A, 400V~ 3L+N+PE, 6h
EBIHB						2	2x4,5				
EIIGB						1	9				
EIIHB						2	2x4,5				
EBIAB				Glatt	Analog	1	9	9			
EBIBB						2	2x4,5				
EIIAB						1	9				
EIIBB						2	2x4,5				

Verwendungsbereich 770x750x250	Toleranz nach DIN ISO 2768-mK	Oberflächen DIN ISO 1302	Maßstab: 1:10 Werkstoff AlSi 304	Gewicht: 102 Kg
Name	Datum	Elektro Bratplatte "OKINAVA"		
Bearb. G.N.	05.05.2020			
HEIDEBRENNER		E_I_B - Einbaugerät		A3

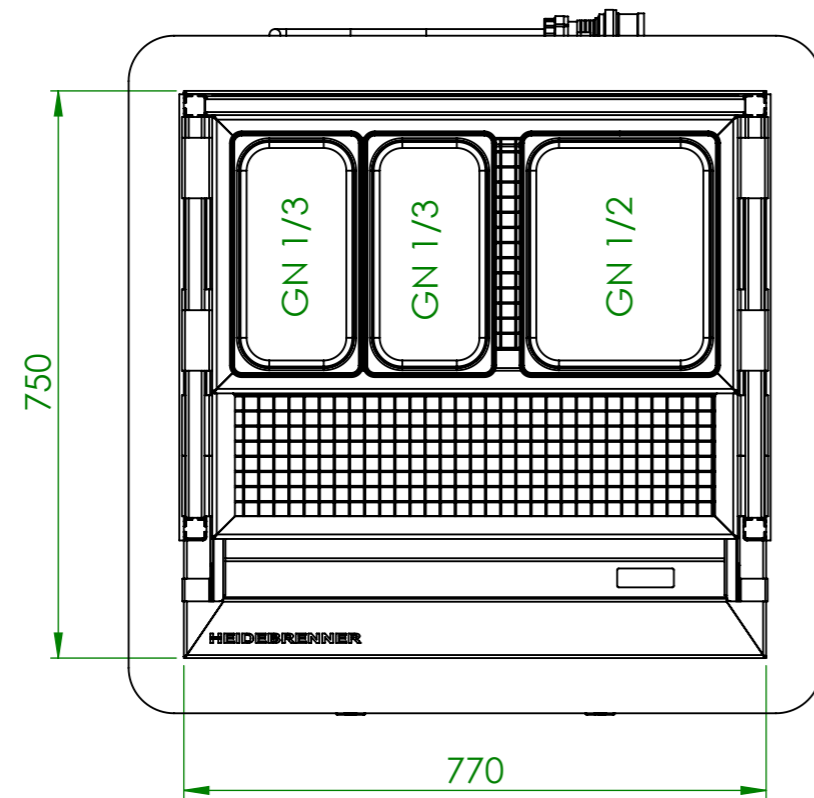

- ZBDN
Auflage für 1/3 GN
- ZBSN
Etagere
- ZBUN
Auflage mit 2/3 Gitterrost
- ZBVN
Auflage mit 1/3 Gitterrost

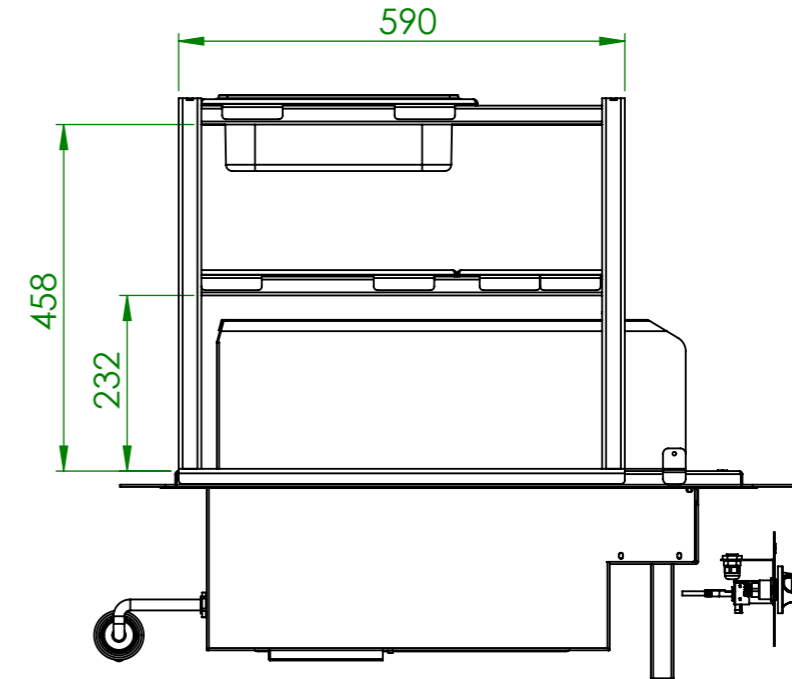
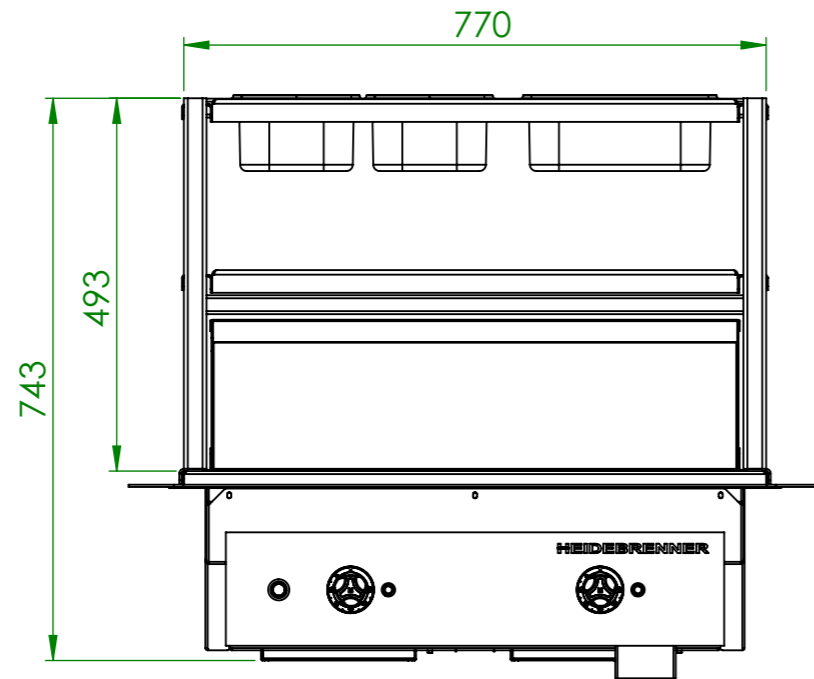
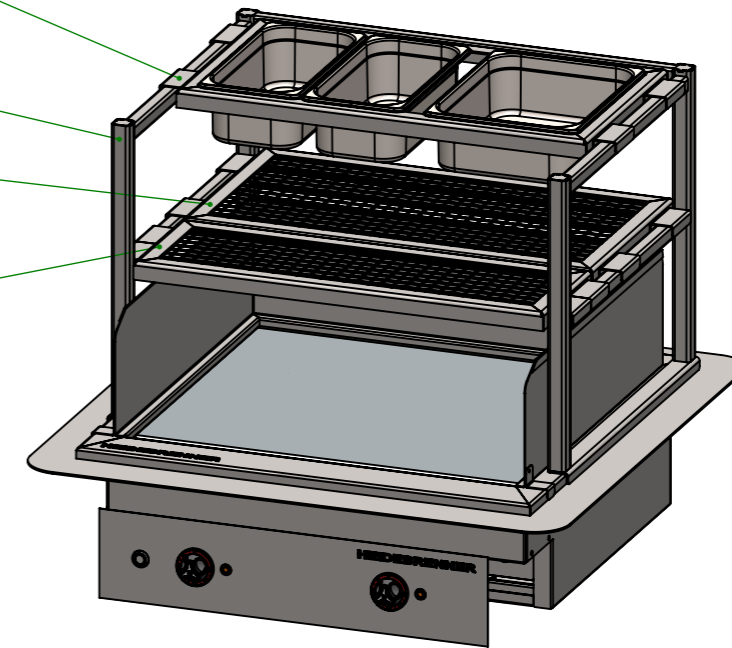

Verwendungsbereich 770x750x743	Toleranz nach DIN ISO 2768-mK	Oberflächen DIN ISO 1302	Maßstab: 1:10	Gewicht: 127 Kg
			Werkstoff AISI 304	
Name	Datum		Elektro Bratplatte "OKINAVA"	
Bearb. G.N.	11.05.2020			
HEIDEBRENNER			E_I_B - Einbaugerät	
				A3

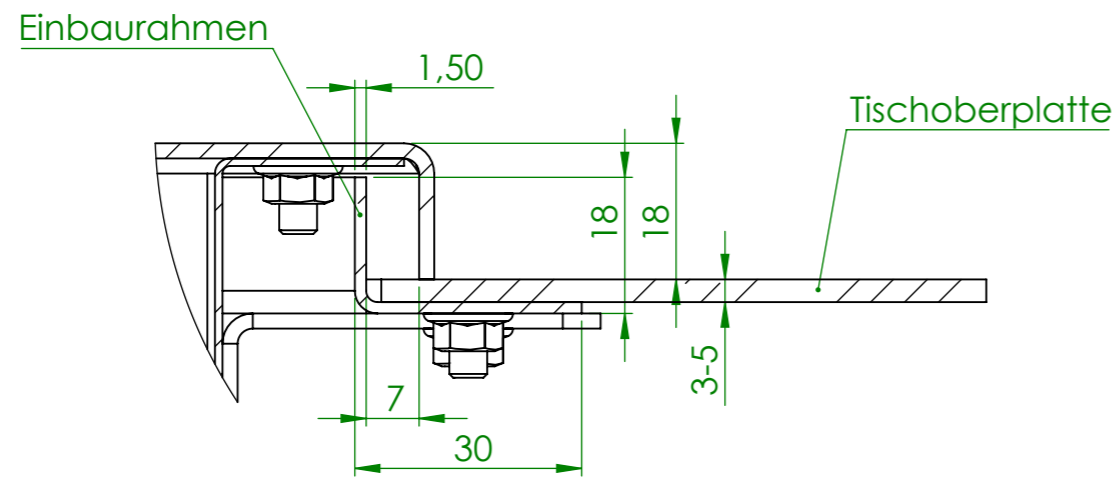

B (1 : 1)

AUSSCHNITTMASS

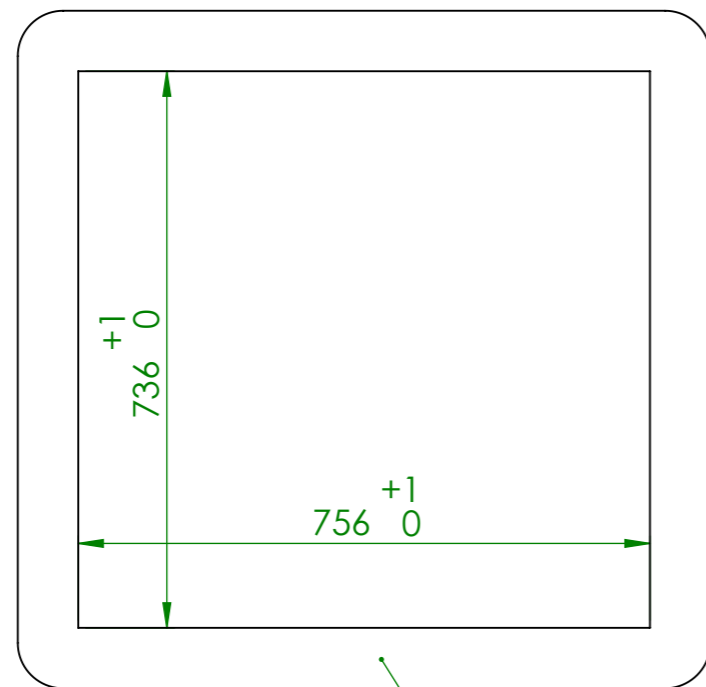

Tischoberplatte

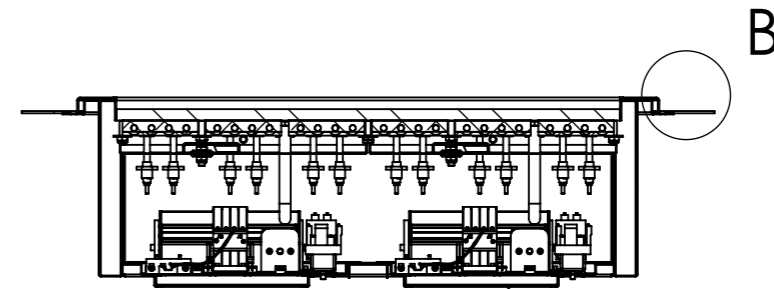

B-B

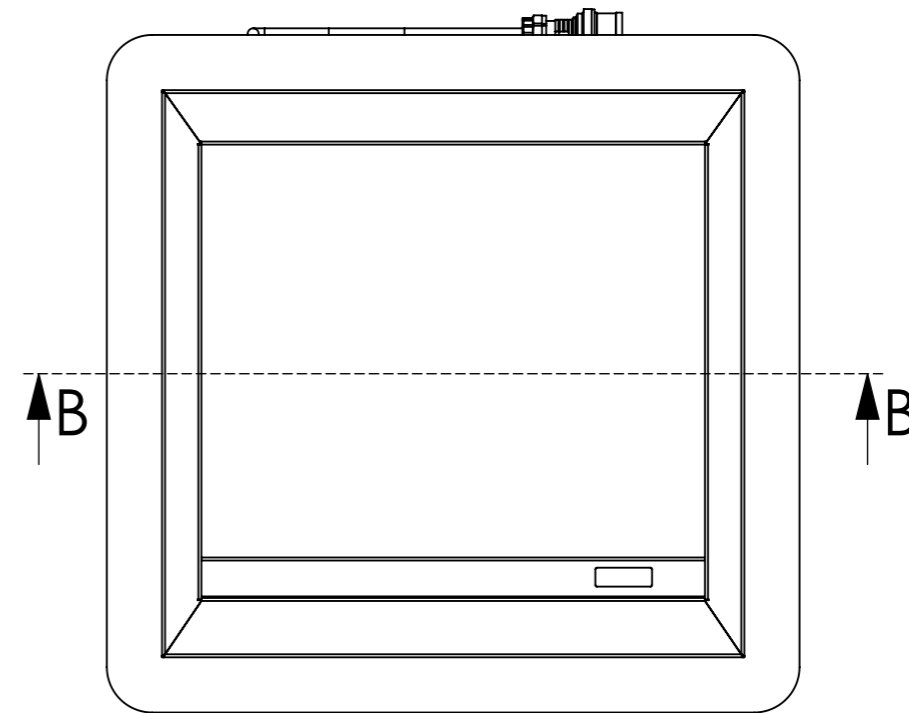

Gerät

Verwendungsbereich 770x750x250	Toleranz nach DIN ISO 2768-mK	Oberflächen DIN ISO 1302	Maßstab: 1:10	Gewicht: 102 Kg
			Werkstoff AISI 304	
Name	Datum		Elektro Bratplatte "OKINAVA"	
Bearb. G.N.	24.04.2020			
HEIDEBRENNER		E_I_B - Einbaugerät		A3