

Verwendungsbereich 1730x550x590	Toleranz nach DIN ISO 2768-mK	Oberflächen DIN ISO 1302	Maßstab: 1:16	Gewicht: 219.58 kg
			Werkstoff 1.4301	
Name	Datum	Gas Lavastein Grill LIPARI		
Bearb. M.B.	15.07.2020			
HEIDEBRENNER		GMAE		A3

Artikel Nr.	P [kW]	Pges [kW]	Volumenstrom V [m3/h]	Gasanschluß [Zoll]	Länge Verbrauchsleitung [m] delta p=0.6mBar
GMAE	5x7,5	37,5	3.97	1"	6

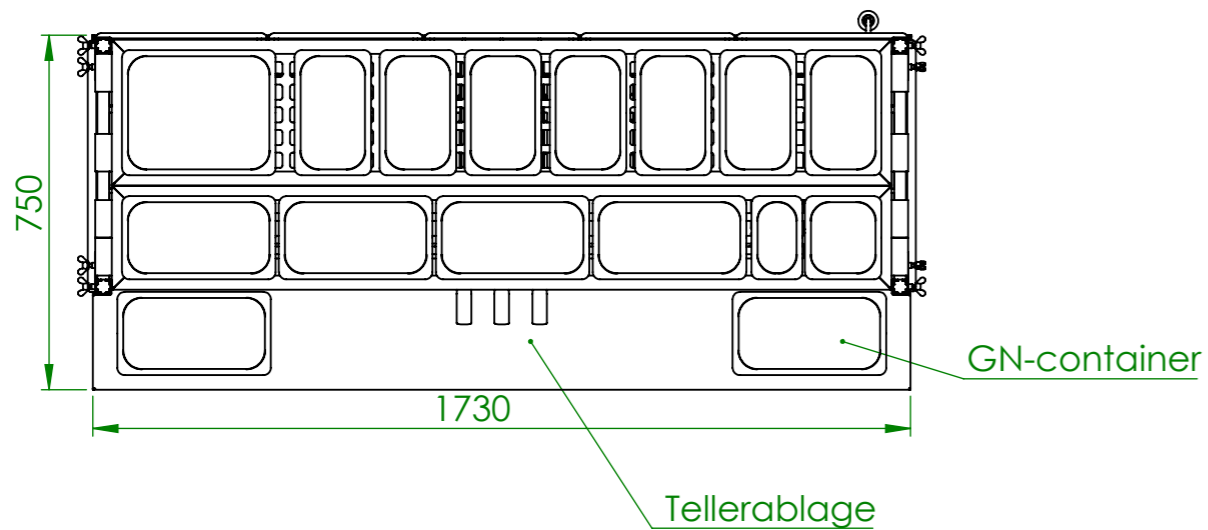
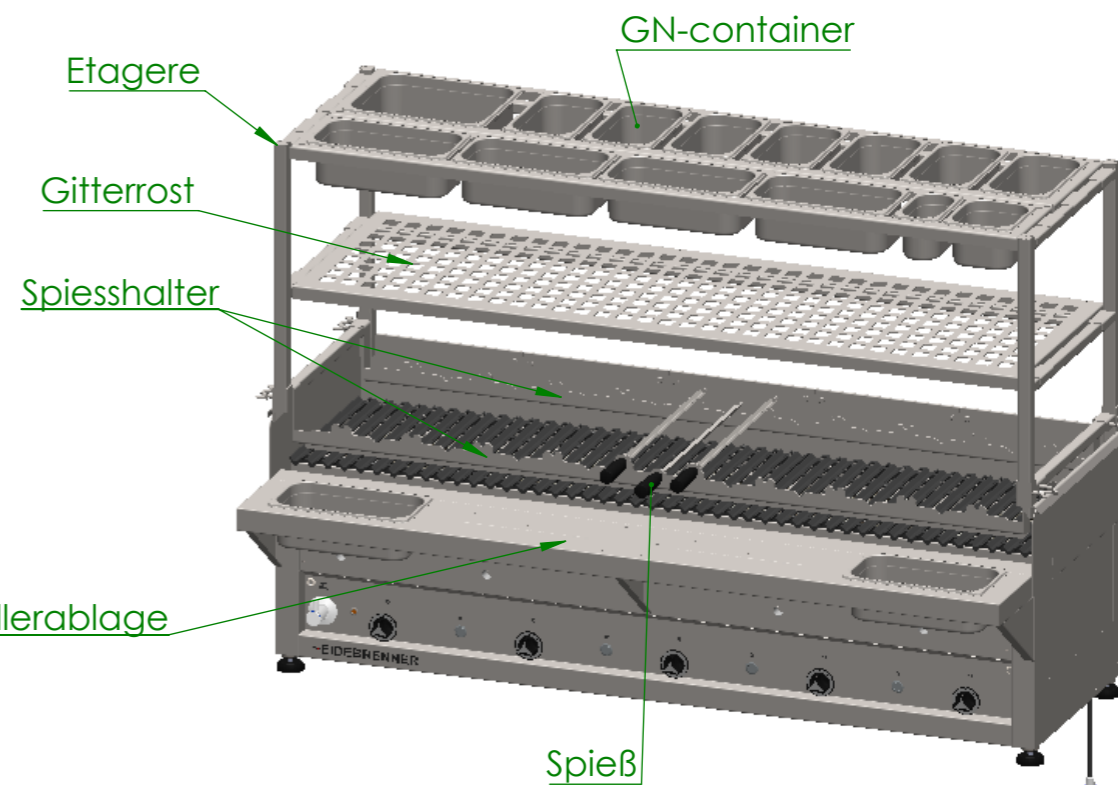
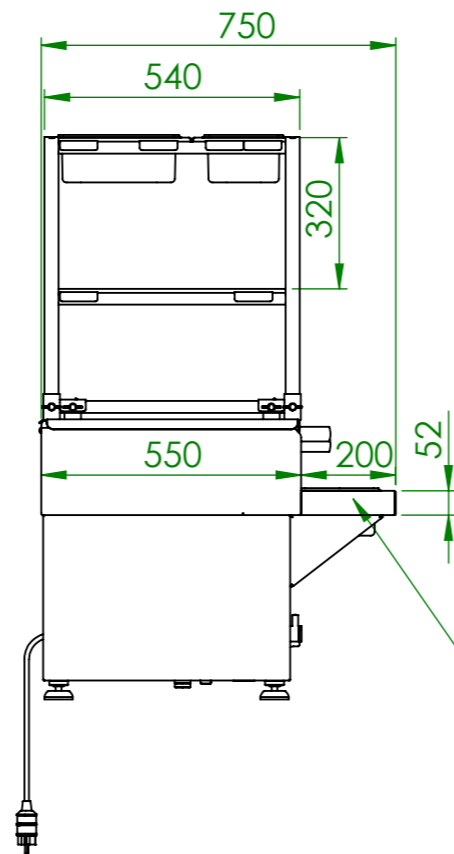
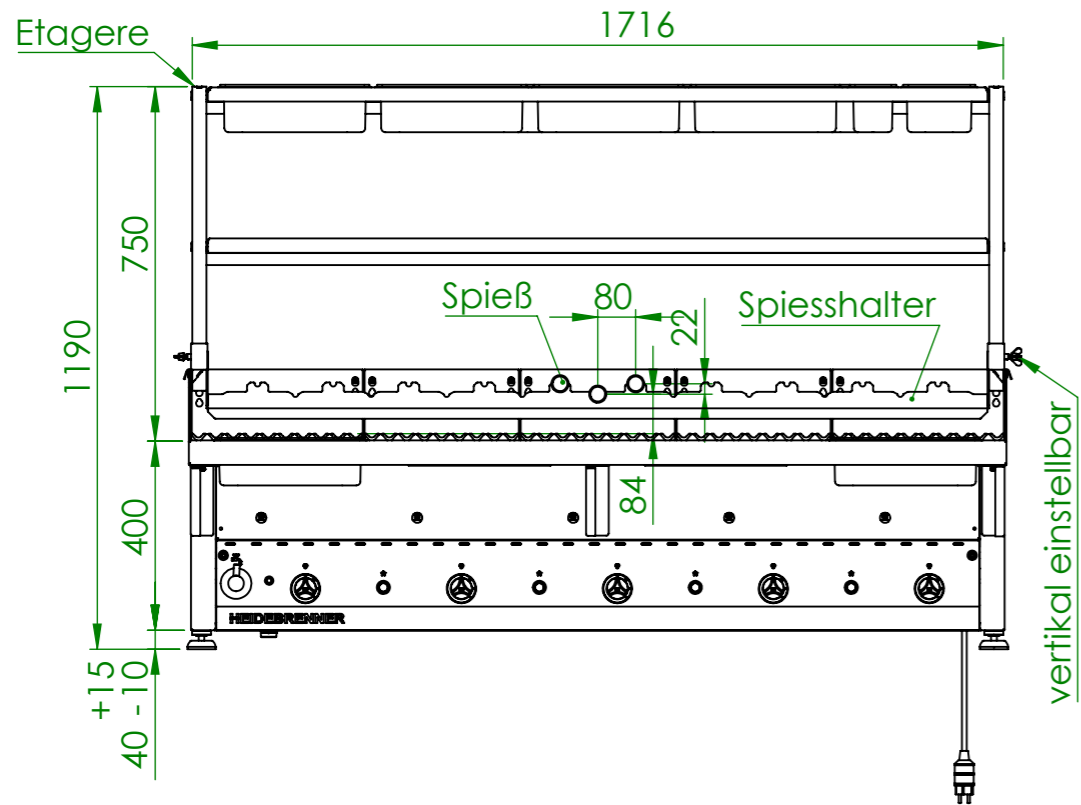

Verwendungsbereich 1730x750x1190	Toleranz nach DIN ISO 2768-mK	Oberflächen DIN ISO 1302	Maßstab: 1:16 Werkstoff 1.4301 AISI 304	Gewicht: 277 kg
Name	Datum	Gas Lavastein-Grill LIPARI		
Bearb. M.B.	15.07.2020			
HEIDEBRENNER		GMAE		A3