

SCHNITT A-A

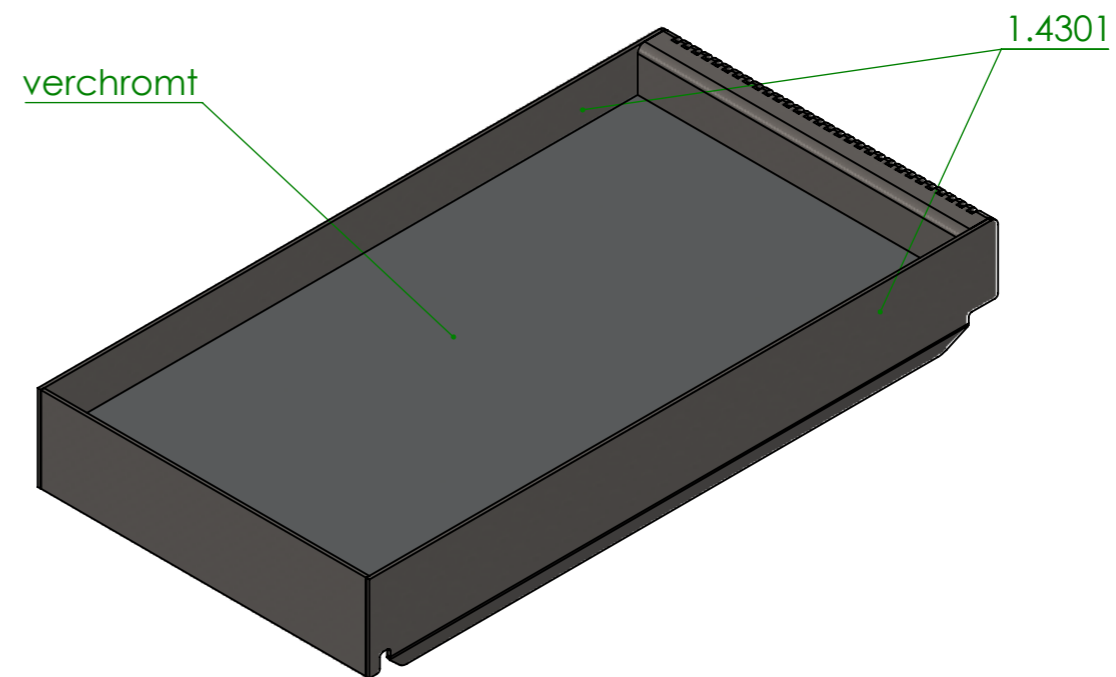
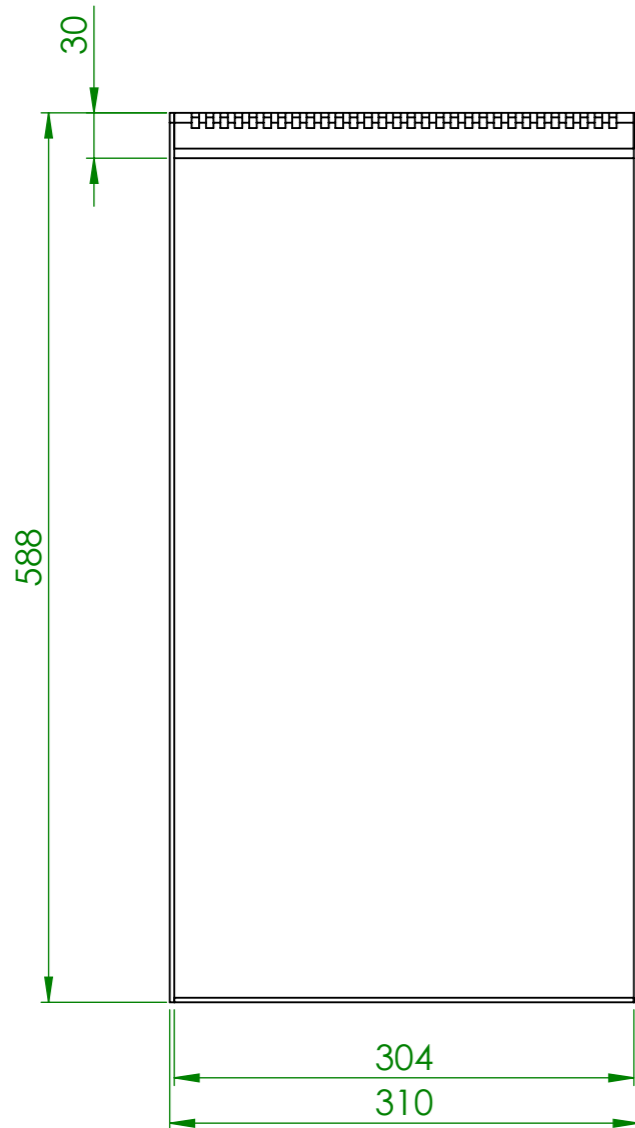

Verwendungsbereich 310x588x90	Toleranz nach DIN ISO 2768-mK	Oberflächen DIN ISO 1302	Maßstab: 1:5	Gewicht: 23.37
			Werkstoff 1.0570	
Name	Datum	Brat Aufsatz verchr. L750 Multibräter		
Bearb. A.G.	05.09.2018			
<b>HEIDEBRENNER</b>		<b>ZCZH</b>		A3