

Hebevorrichngsrad

Grill Rost

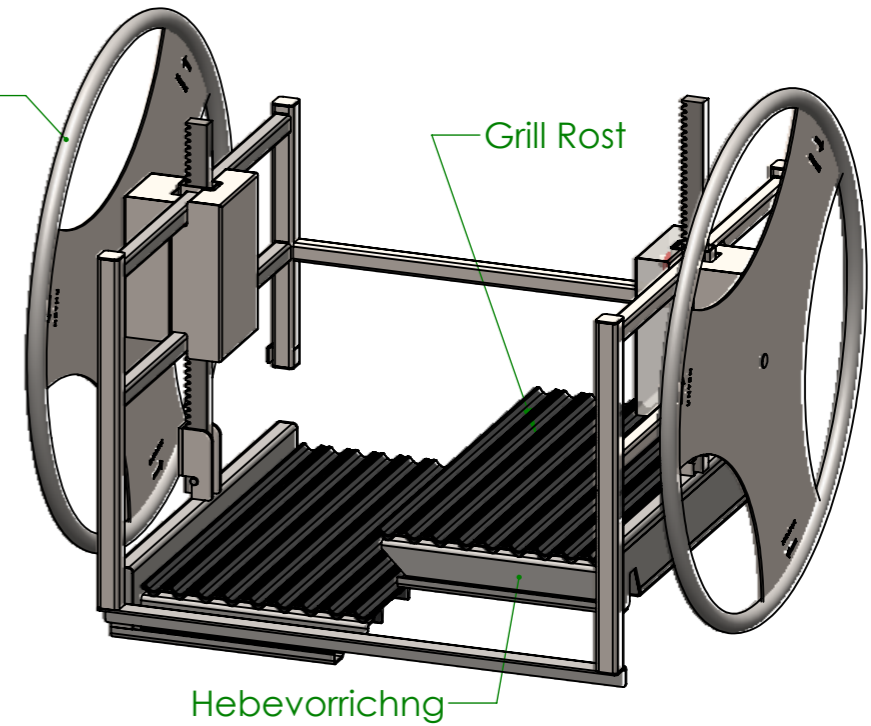

Hebevorrichng

Verwendungsbereich 920x726x752	Toleranz nach DIN ISO 2768-mK	Oberflächen DIN ISO 1302	Maßstab: 1:10	Gewicht: 73.81 Kg
			Werkstoff 1.4301	
Name	Datum	Etagere Grill mit Hebevorrichtung		
Bearb. M.B.	31.08.2021			
ZCZN			A3	