

Artikel Nr.	HZ	P [kW]	Pges [kW]	Volumenstrom V [m ³ /h]	Gasanschluß [Zoll]	Länge Verbrauchsleitung [m] delta p=0.6mBar
GMKE	5	12,8	64,0	6,77	1"	6

Verwendungsbereich 1730x900x1000	Toleranz nach DIN ISO 2768-mK	Oberflächen DIN ISO 1302	Maßstab: 1:16 Werkstoff 1.4301	Gewicht: 355.39 kg
Name	Datum	Gas Lavastein-Grill LIPARI		
Bearb. M.B.	14.07.2020			
HEIDEBRENNER		GMKE		A3

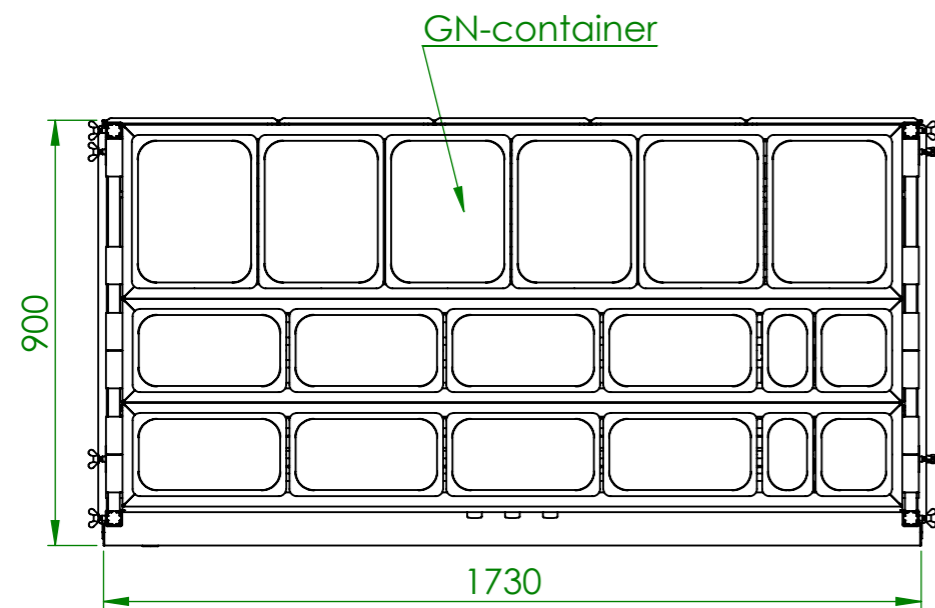
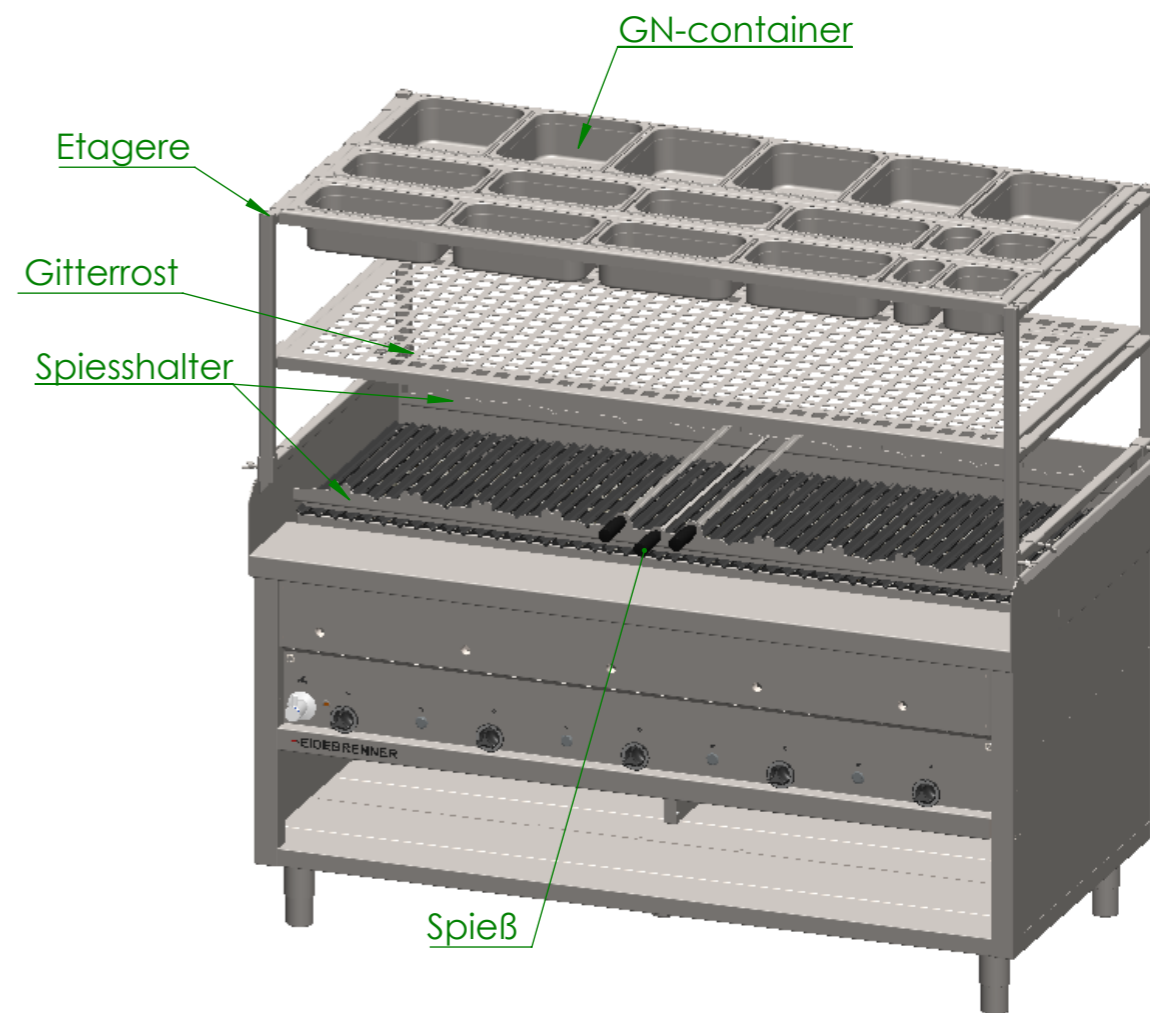
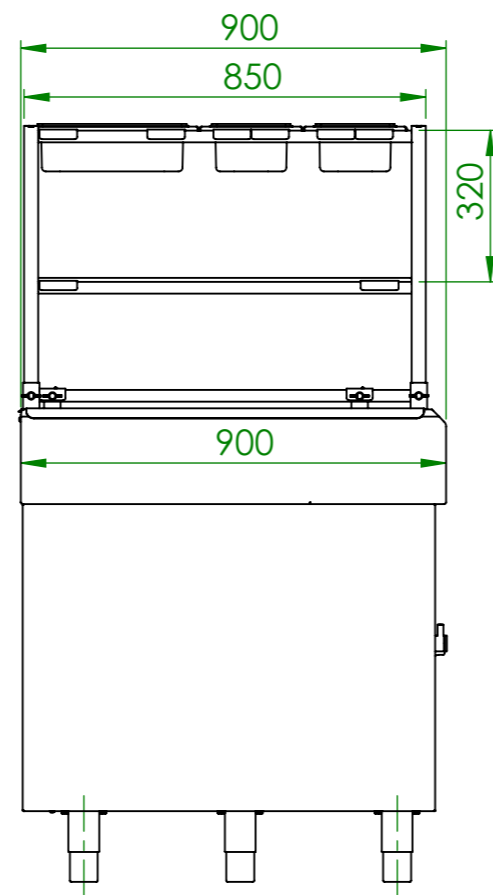
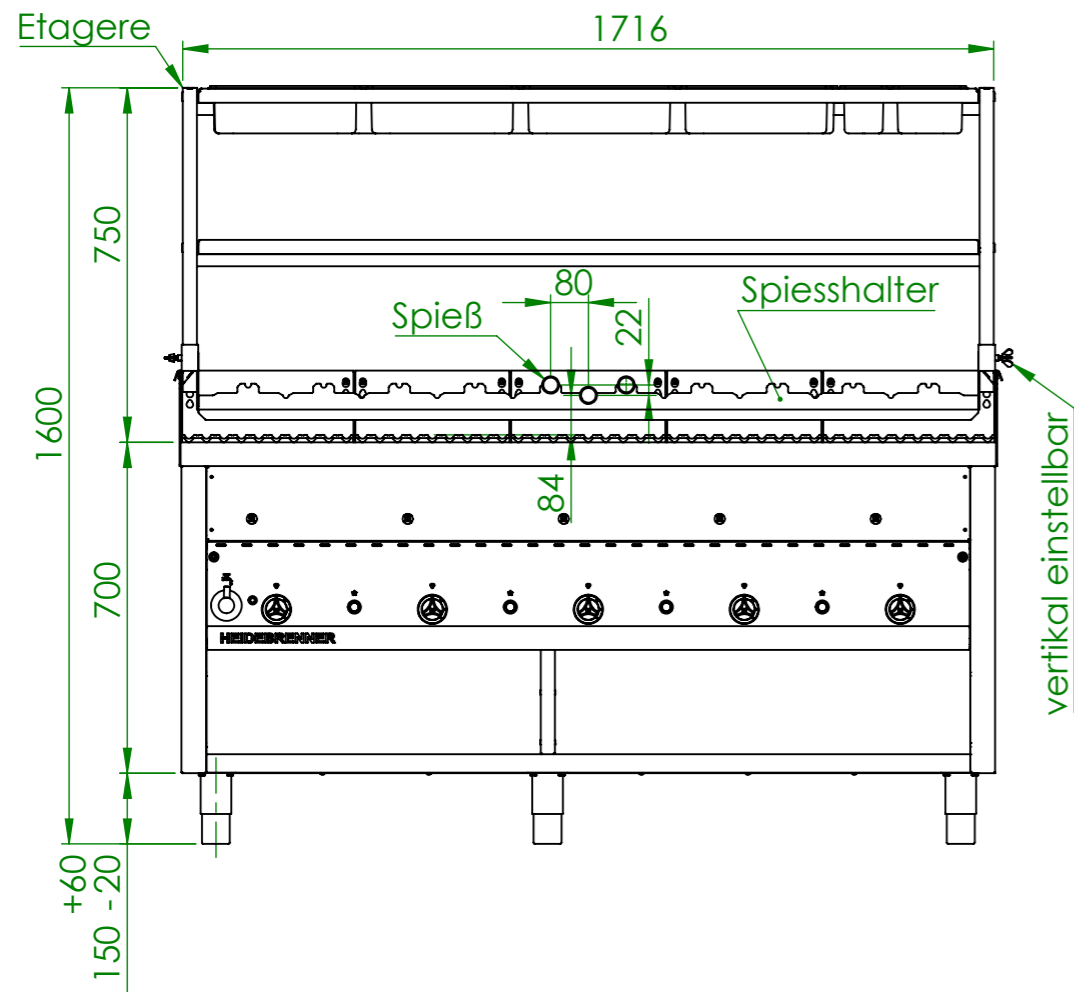

Verwendungsbereich 1730x900x1600	Toleranz nach DIN ISO 2768-mK	Oberflächen DIN ISO 1302	Maßstab: 1:16 Werkstoff 1.4301 AISI 304	Gewicht: 417 kg
Name	Datum	Gas Lavastein-Grill LIPARI		
Bearb. M.B.	14.07.2020			
HEIDEBRENNER		GMKE+Etagere		A3