

Verwendungsbereich 1997x750x850	Toleranz nach DIN ISO 2768-mK	Oberflächen DIN ISO 1302	Maßstab: 1:10	Gewicht: 215 kg
		Werkstoff 1.4301 AISI 304		
Name	Datum	Elektro Lava/Wasser Grill GEYSIR		
Bearb. G.N.	07.07.2020			
HEIDEBRENNER		EFH_F - Standgerät		A3

Art. Nr	HZ	P[kW]	Wasser	Abwasser	Strom
EFHCF	3	3 x 9	G 1/2"	DN 50	CEE 63 A, 400V~ 3L+N+PE, 6h
EFHFF	6	6 x 4,5			

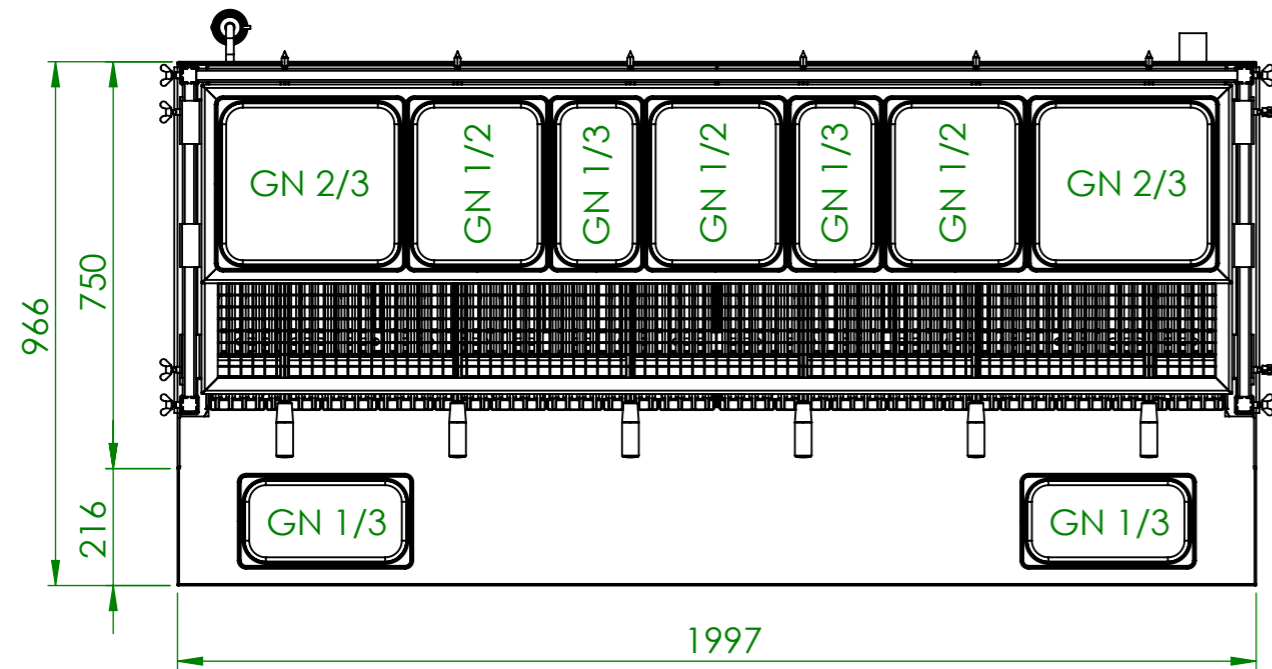

- ZQDR - 325 GN Halter
- ZQTR - 1/1 Gitterrost
- ZQSR - Etager
- ZMQR - Spiesshalter
- Spieß
- ZQXR - GN Halter

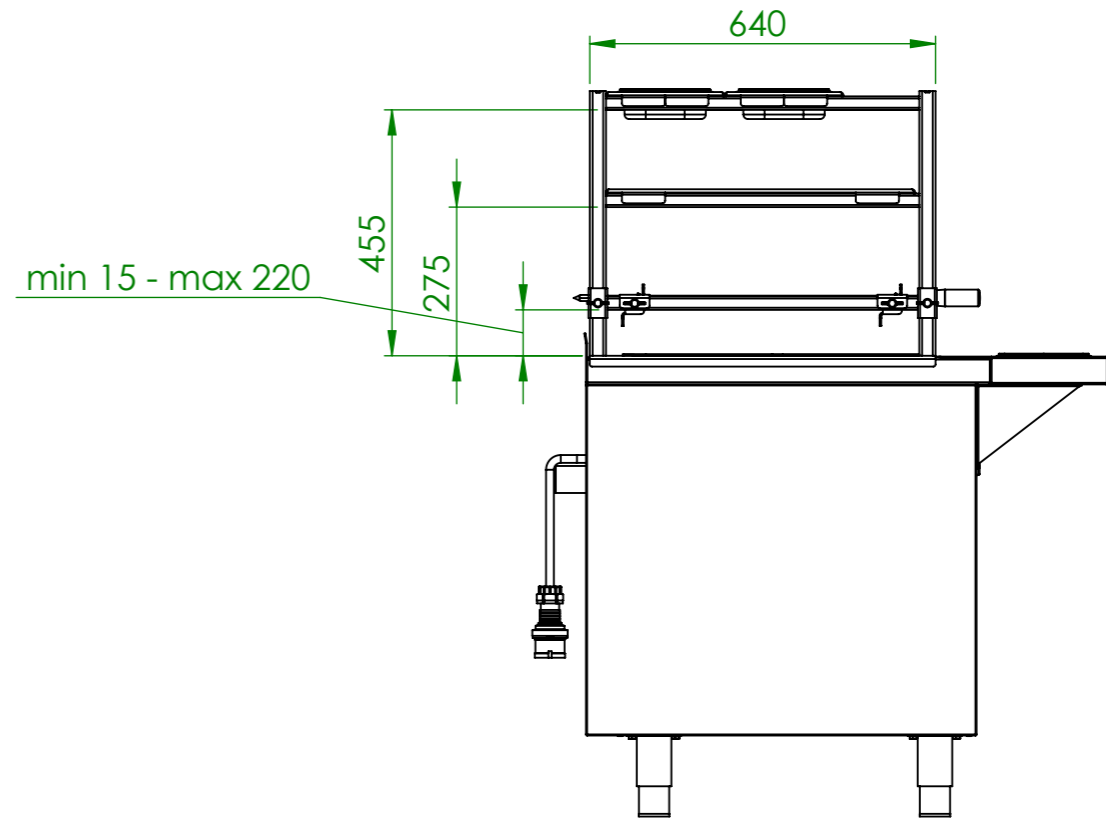
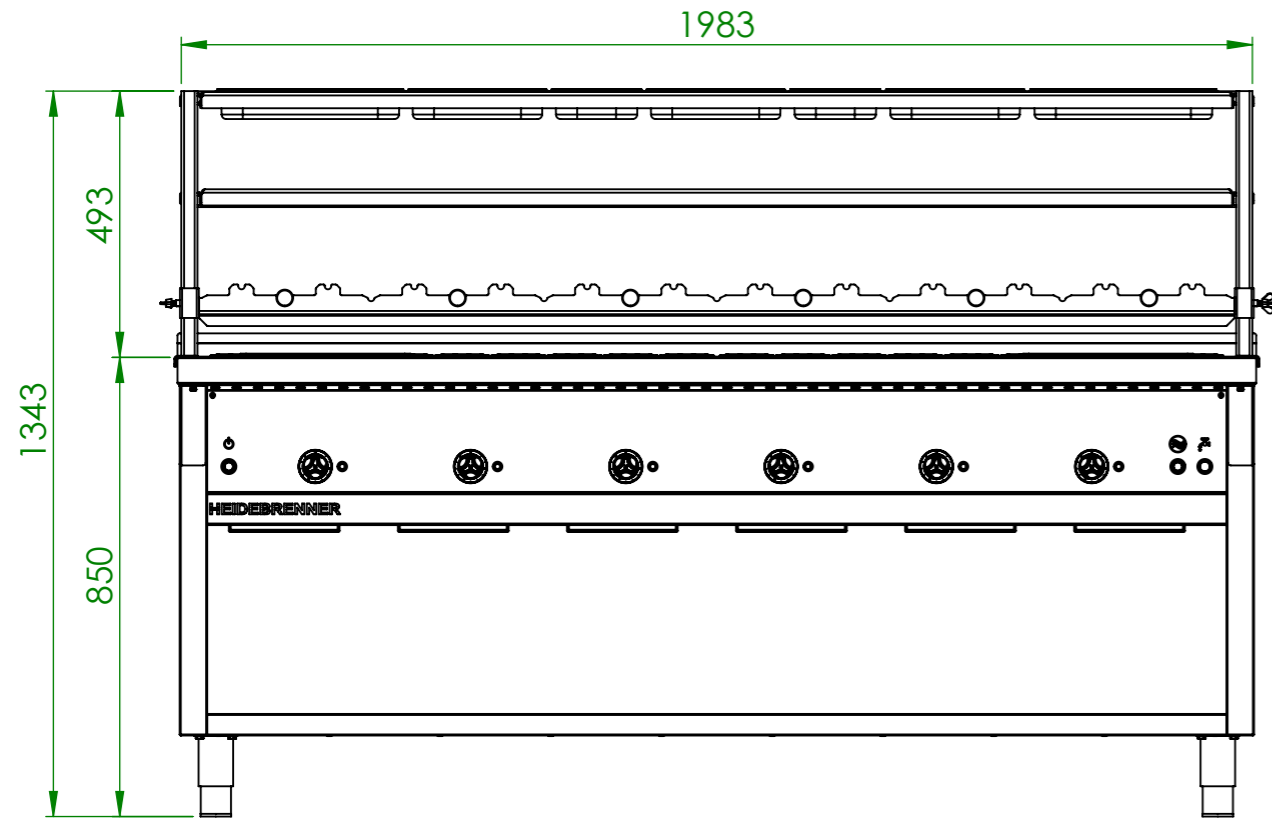
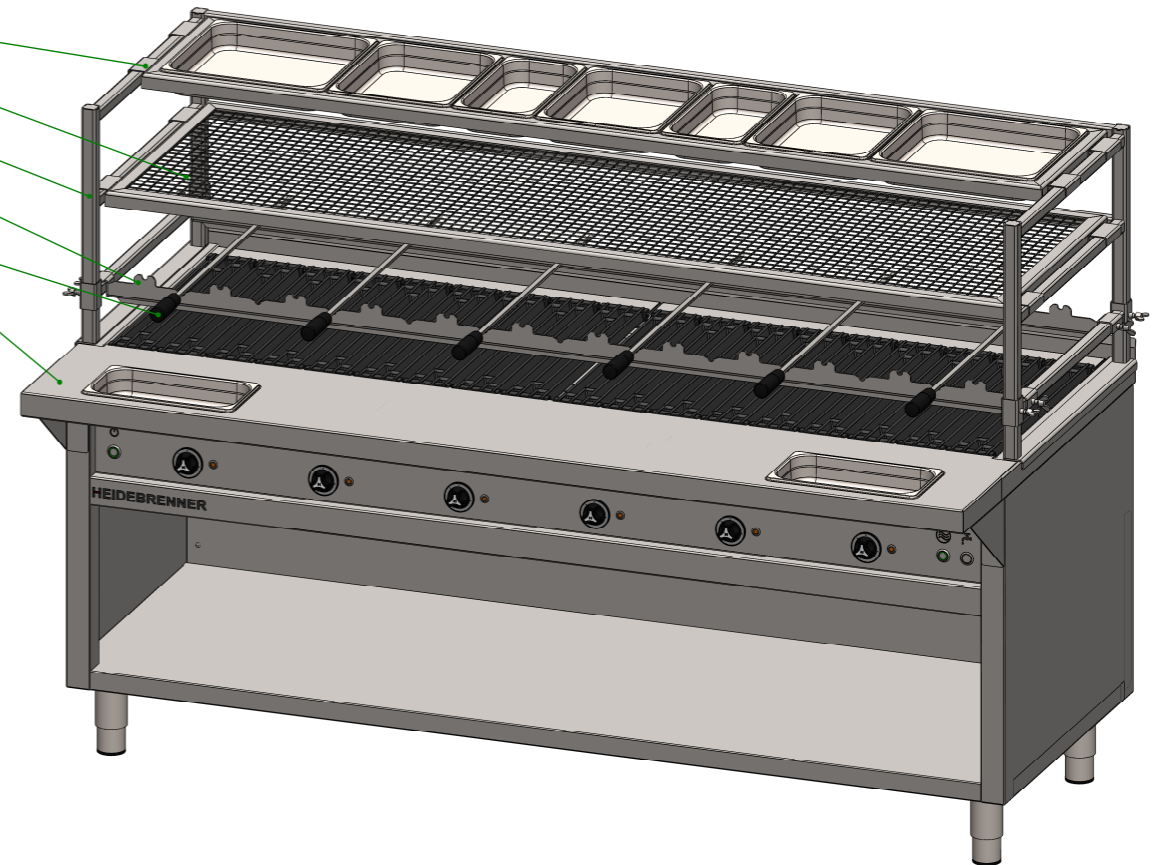

Verwendungsbereich 1997x966x1343	Toleranz nach DIN ISO 2768-mK	Oberflächen DIN ISO 1302	Maßstab: 1:14	Gewicht: 283 kg
		Werkstoff 1.4301 AISI 304		
Name	Datum	Elektro Lava/Wasser Grill GEYSIR		
Bearb. G.N.	02.04.2020			
HEIDEBRENNER		EFH_F + ETAGERE		A3