

Verwendungsbereich 1275x900x850	Toleranz nach DIN ISO 2768-mK	Oberflächen DIN ISO 1302	Maßstab: 1:12	Gewicht: 167 kg
Name	Datum	Werkstoff 1.4301 AISI 304		
Bearb. M.G.	15.12.2020	Gas-Range „KALIFORNIEN“		
HEIDEBRENNER		GLM_C		A3

Art.Nr	KochStellen- Brenner	WarzenBrenner	P[kW]	Pges [kW]	Volumenstrom V[m3/h]	Gasanschluß [Zoll]	Länge Verbrauchsleitung [m] delta p=0.6mBar
GLMFC	6	-	5,8	34,8	3,7	1	>20
GLMMC	-	6	8,7	52,2	5,55	1	11

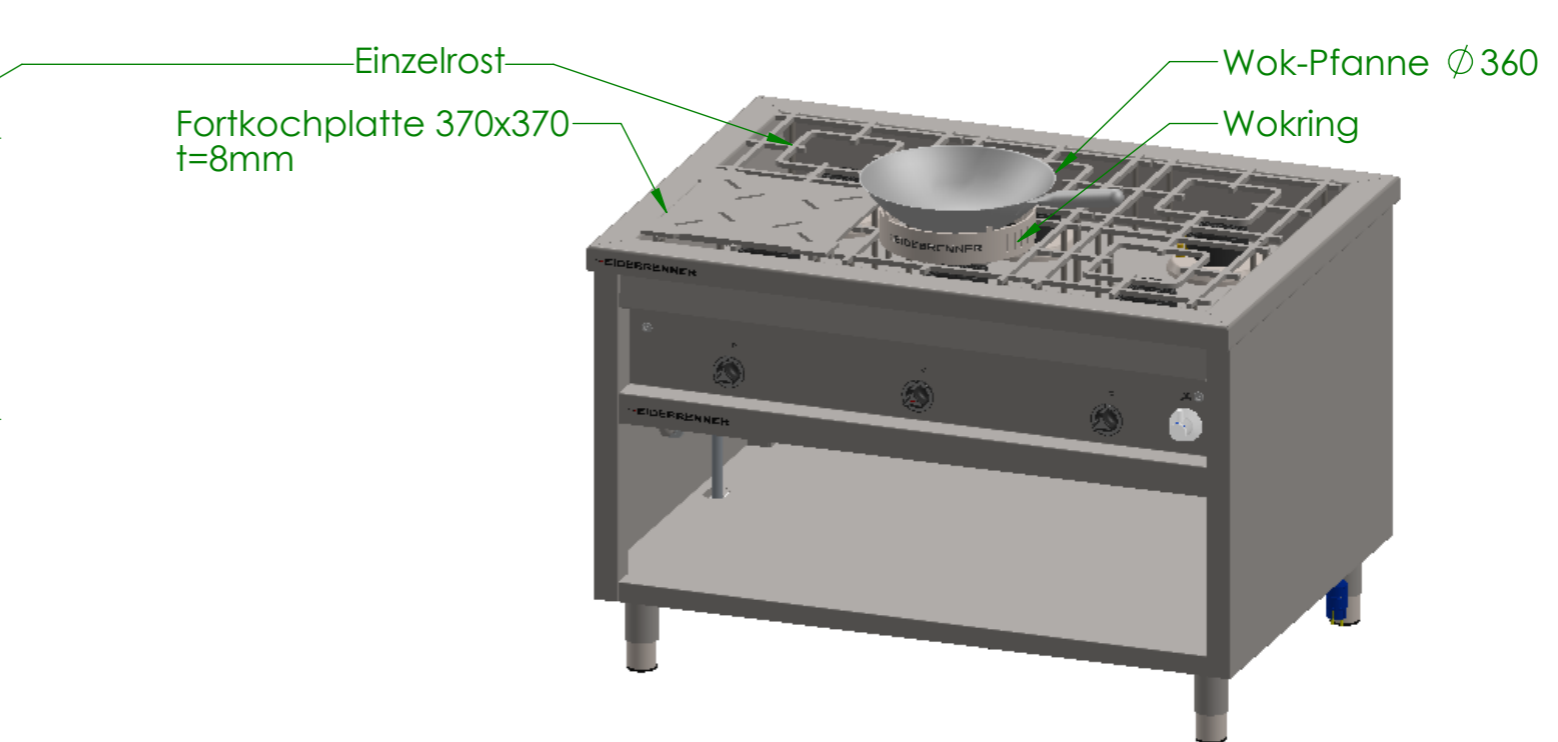
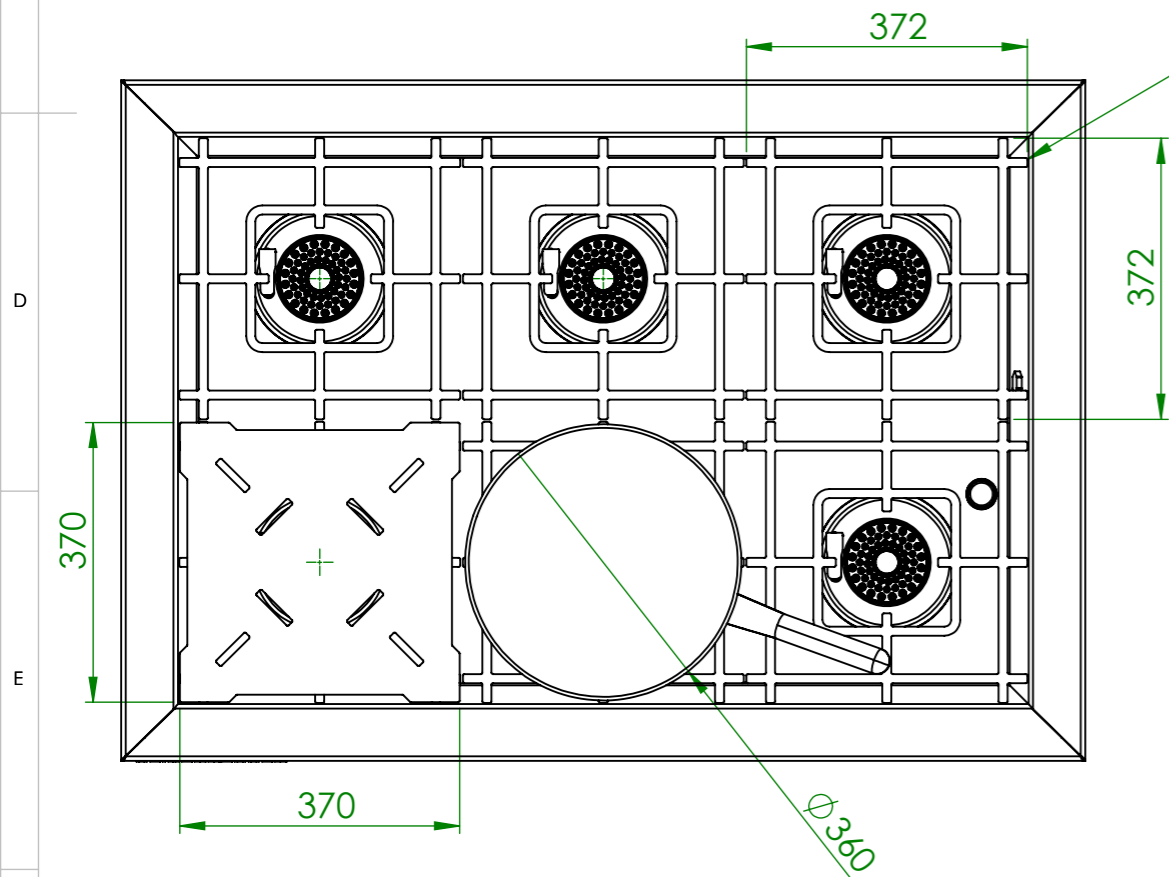
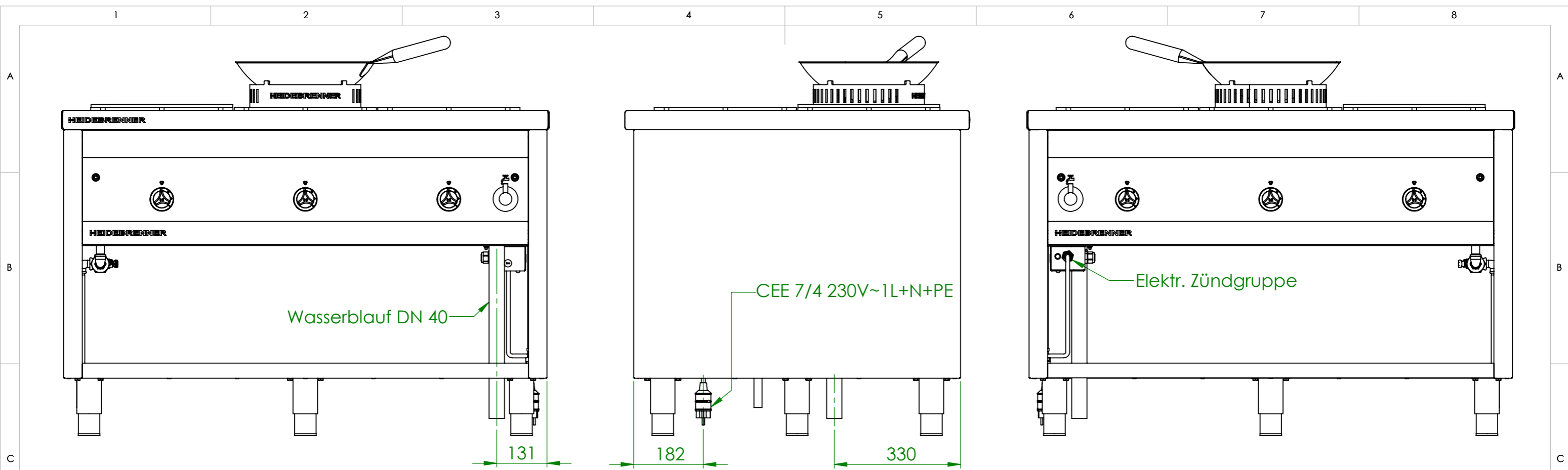

Verwendungsbereich 1275x900x850	Toleranz nach DIN ISO 2768-mK	Oberflächen DIN ISO 1302	Maßstab: 1:10 Werkstoff 1.4301 AISI 304	Gewicht: 181 kg
Name	Datum	Gas-Range „KALIFORNIEN“		
Bearb. M.G.	15.12.2020			
HEIDEBRENNER		GLM_C + Zubehör		A3