

B  
SCALE 1 : 2

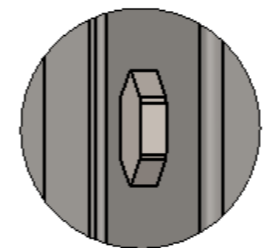

Doppelrost

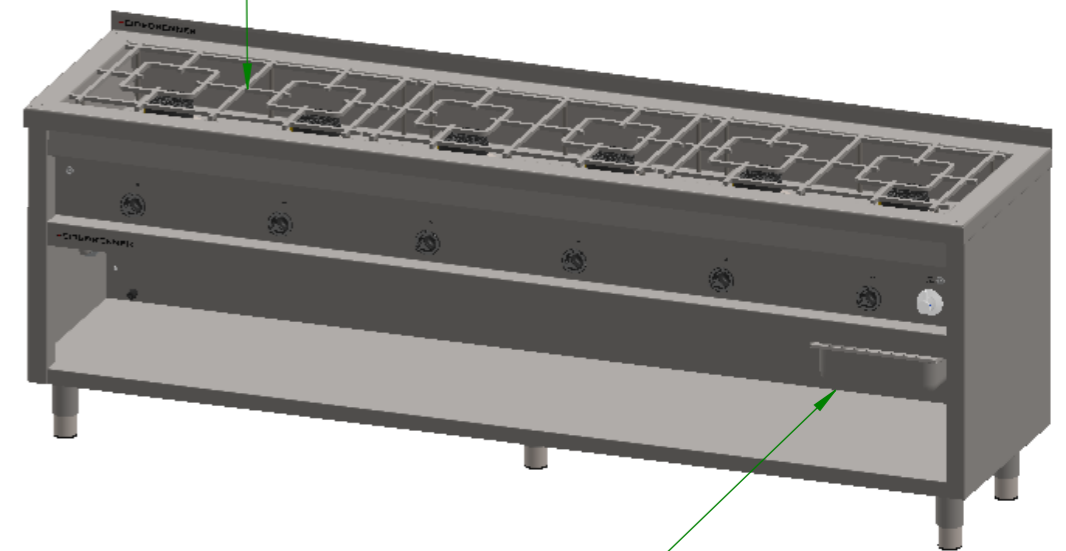

6x KochStellenBrenner für GLBFD  
6x WarzenBrenner für GLBMD

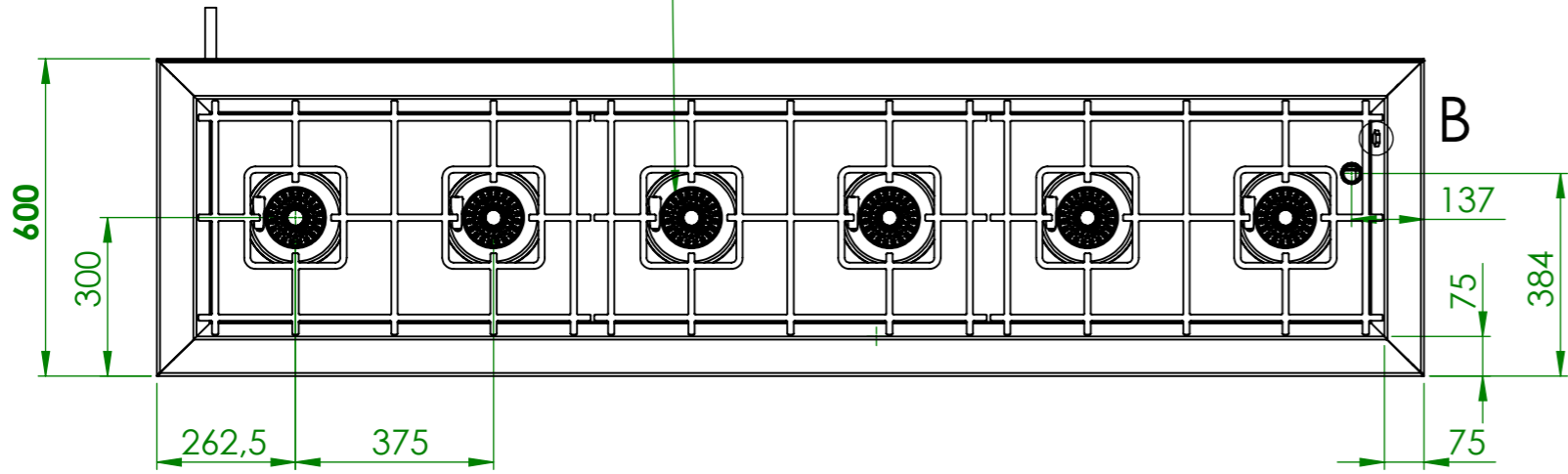

Art.Nr	KochStellen-Brenner	WarzenBrenner	P[kW]	Pges [kW]	Volumenstrom V[m3/h]	Gasanschluß [Zoll]	Länge Verbrauchsleitung [m] delta p=0.6mBar
GLBFD	6	-	5,8	34,8	3,7	1	>20
GLBMD	-	6	8,7	52,2	5,55		11

Verwendungsbereich 2400x600x850	Toleranz nach DIN ISO 2768-mK	Oberflächen DIN ISO 1302	Maßstab: 1:14	Gewicht: 203,5 kg
Name	Datum	Werkstoff 1.4301 AISI 304		
Bearb. M.G.	17.12.2020	Gas-Range „KALIFORNIEN“		
HEIDEBRENNER		GLB_D		A3

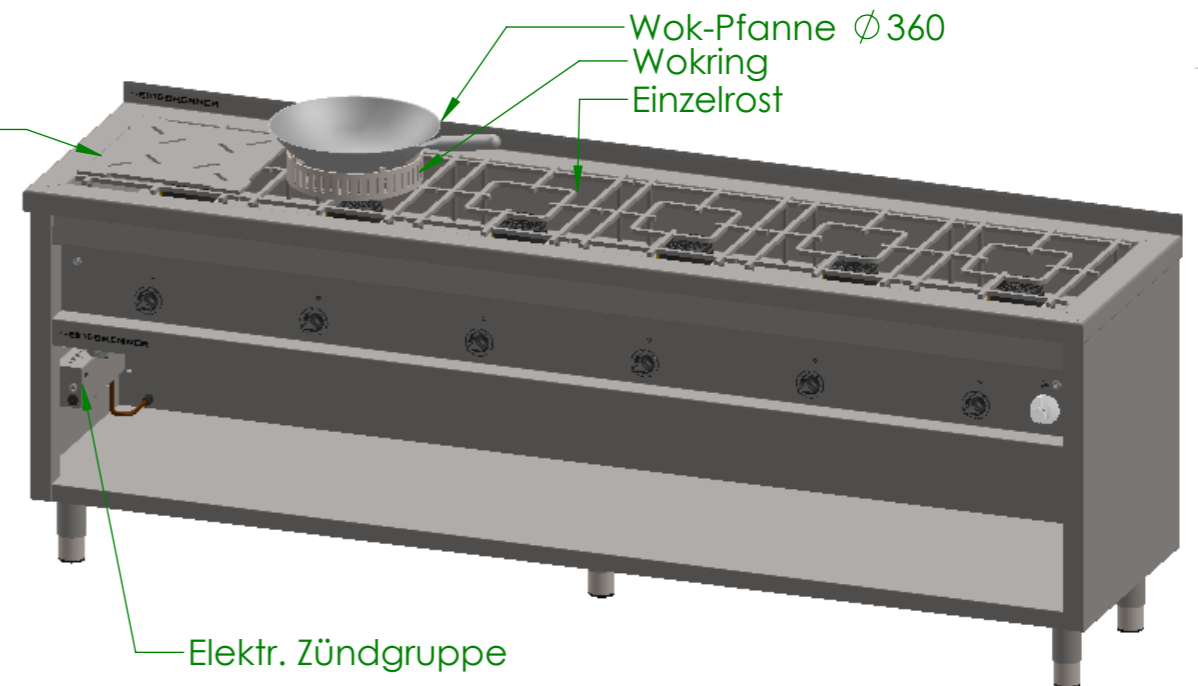
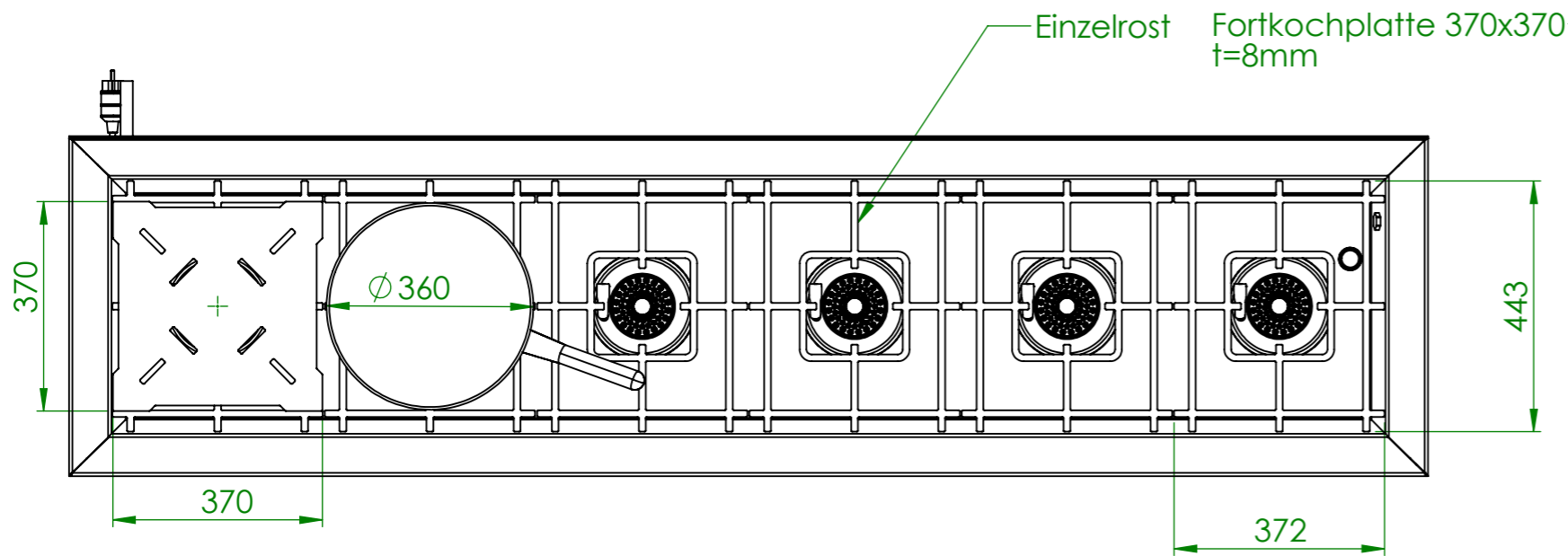
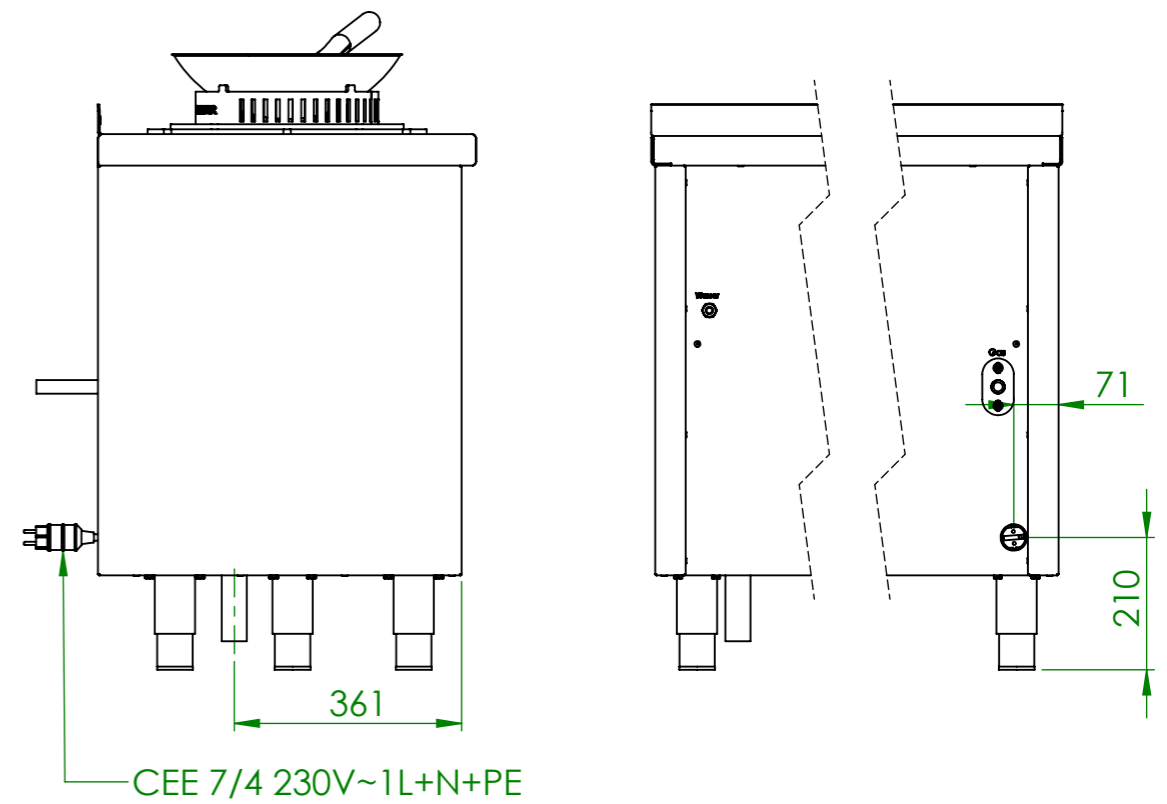
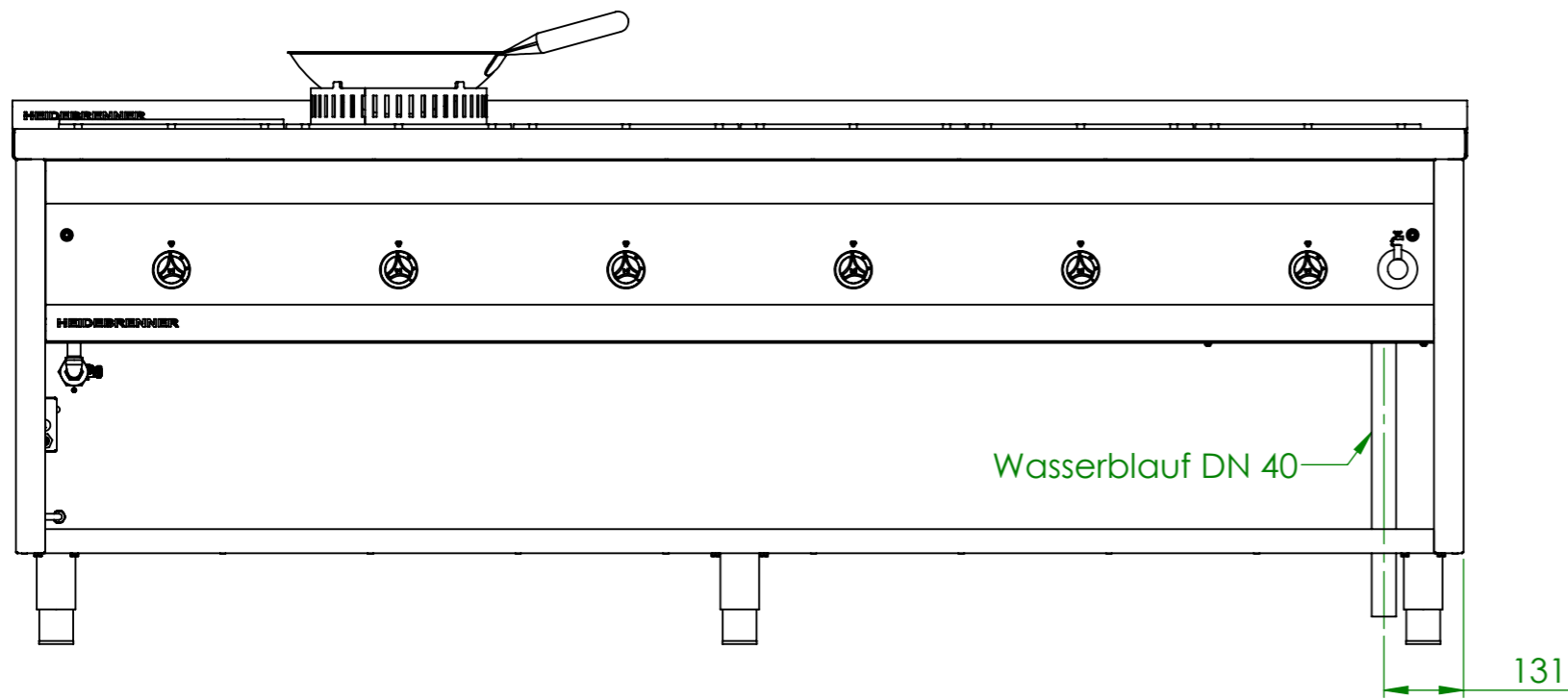

Verwendungsbereich 2400x600x850	Toleranz nach DIN ISO 2768-mK	Oberflächen DIN ISO 1302	Maßstab: 1:12 Werkstoff 1.4301 AISI 304	Gewicht: 218 kg
Name	Datum	Gas-Range „KALIFORNIEN“		
Bearb. M.G.	17.12.2020			
<b>HEIDEBRENNER</b>		GLB_D + Zubehör		A3