

# EPIH

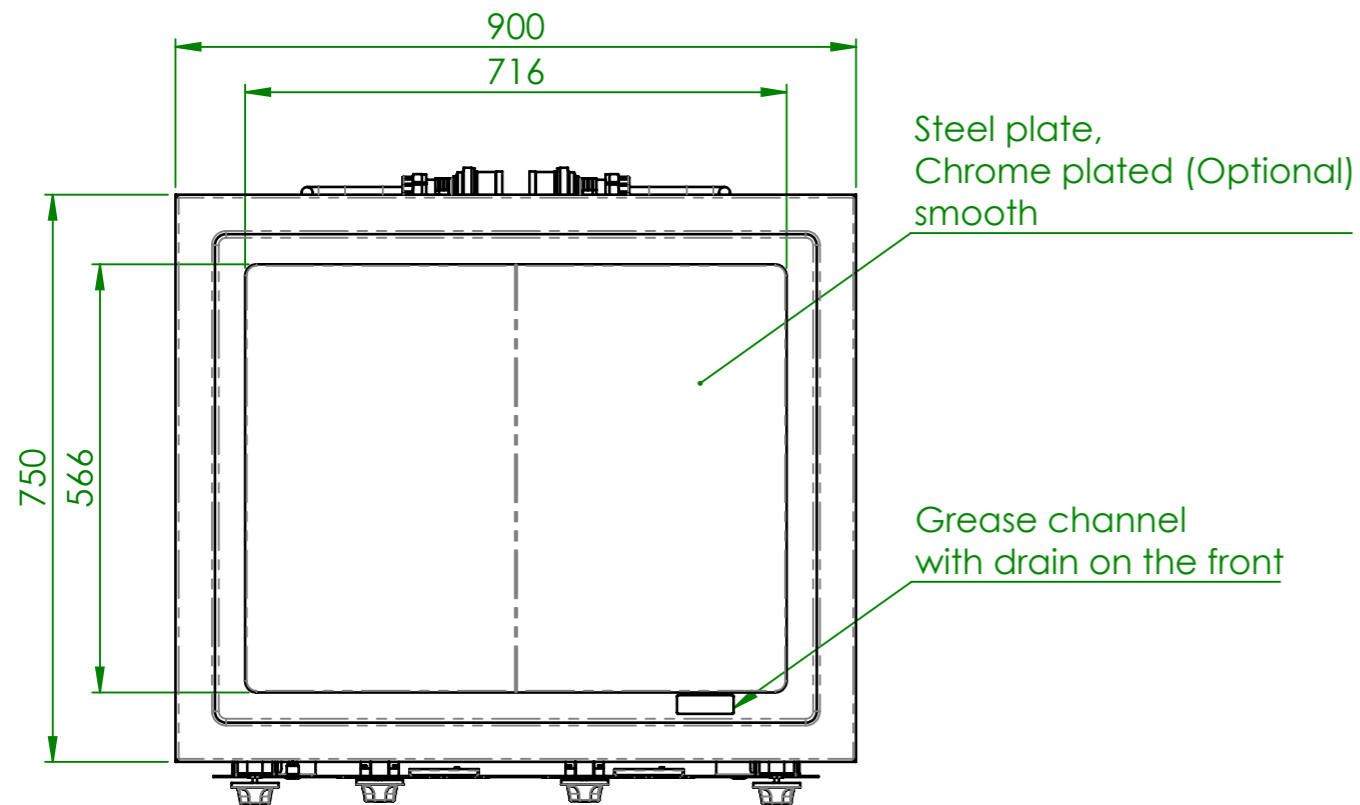
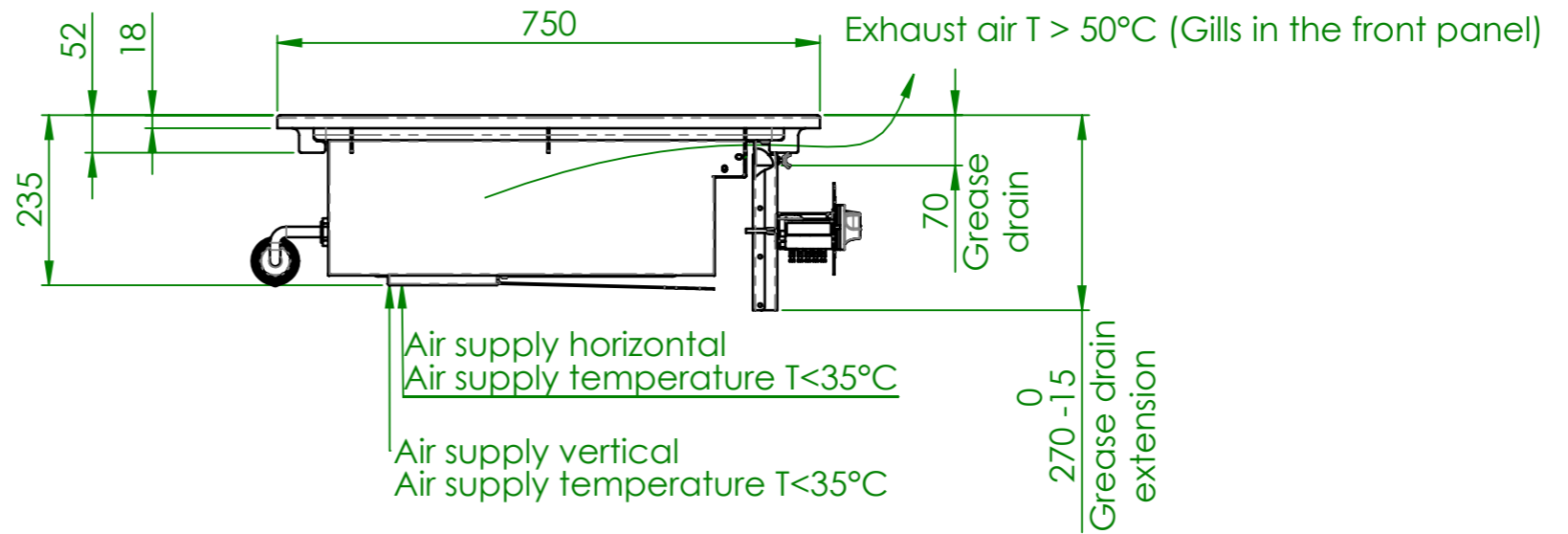
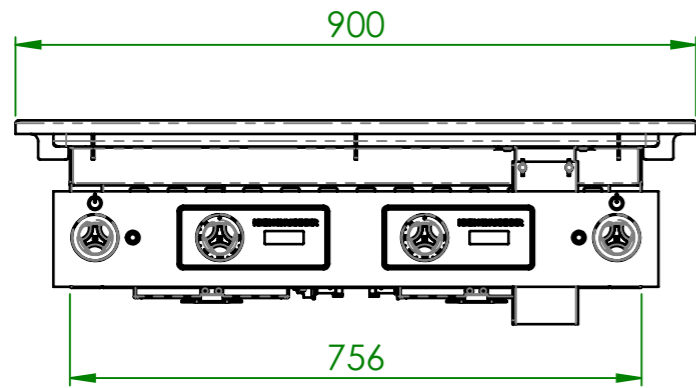

EPI(BH)-ZZ-Rahmen(Optional)

EPIH-ZZ-Blende(Optional)

ON/OFF

Electronic Microstat T=50...400°C with setpoint/actual temperature display

Grease drain extension(Optional)

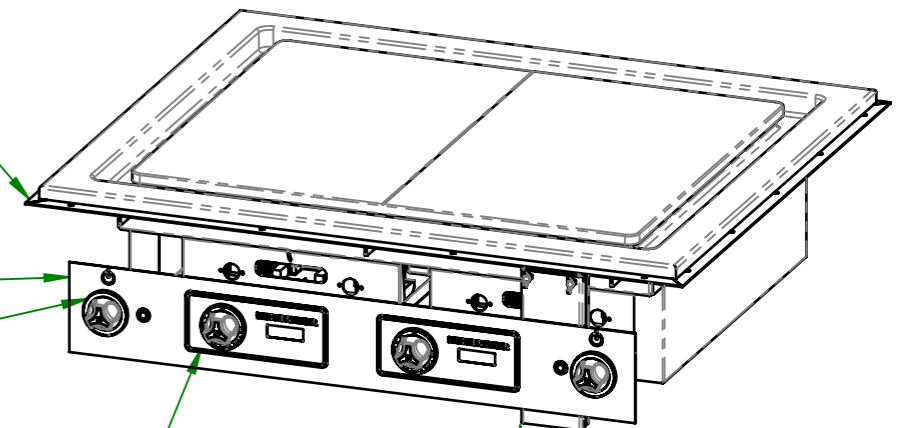

Article Nr	HZ	per HZ [kW]	Ptotal [kW]	Power connector	Circuit breaker	Residual current device	Control
EPIH	2	6	12	2x CEE 16 A, 400V~ 3L+N+PE, 6h	2x B16A 3-pol.	2x Typ A, 40A/0,03A 4-pol.	Digital

VDI 2052 Heat emission	per HZ [kW]
Qdirect	1,47
Qlatent	0,37
Qmoisture	0,54

Verwendungsbereich	Toleranz nach DIN ISO 2768-mK	Oberflächen DIN ISO 1302	Maßstab: 1:10	Gewicht: 110 kg
Name	Datum	French Electric Plancha "NIZZA"		
Bearb. W.K.	18.02.2026	EPI(BH)_eng		
<b>HEIDEBRENNER</b>				A3

# EPIH-W (WELDED)

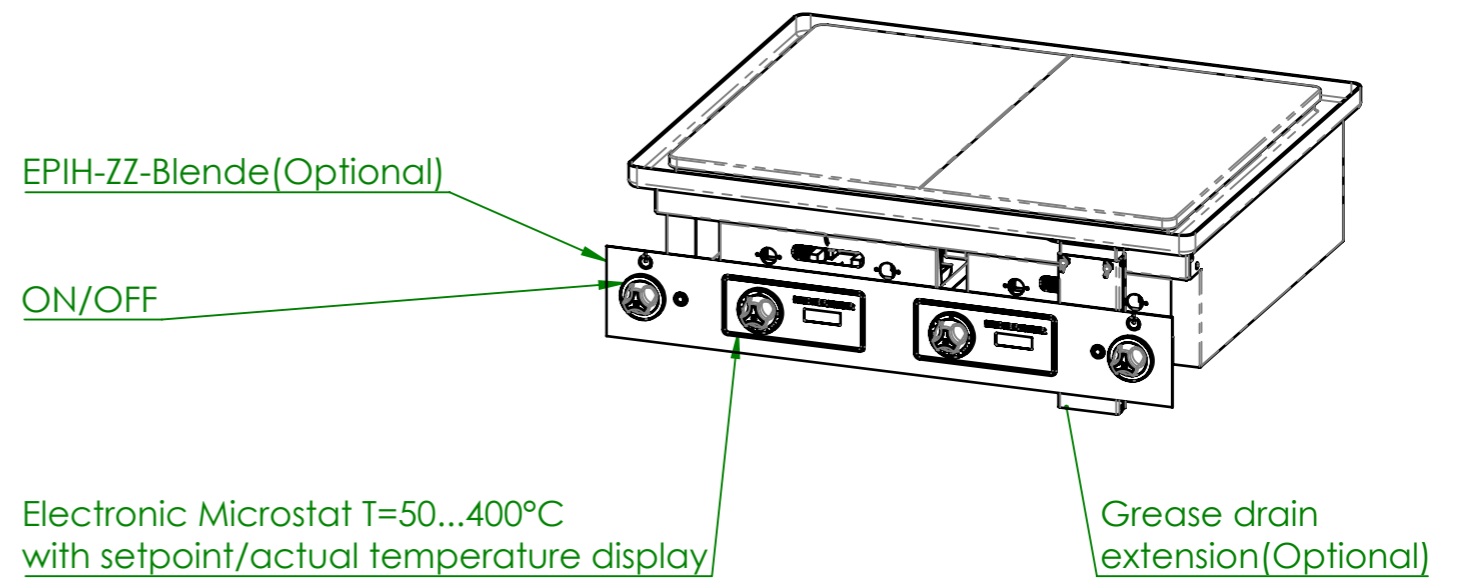
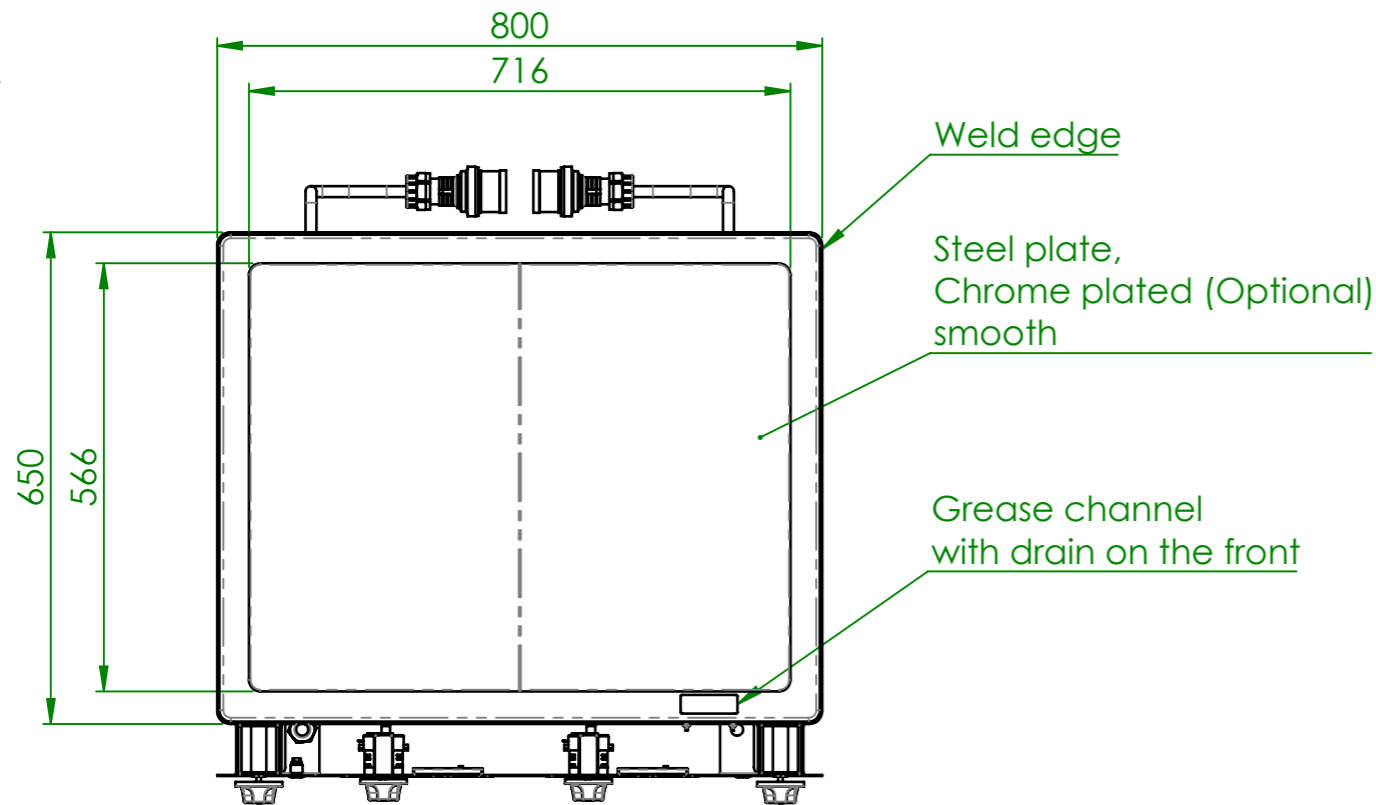
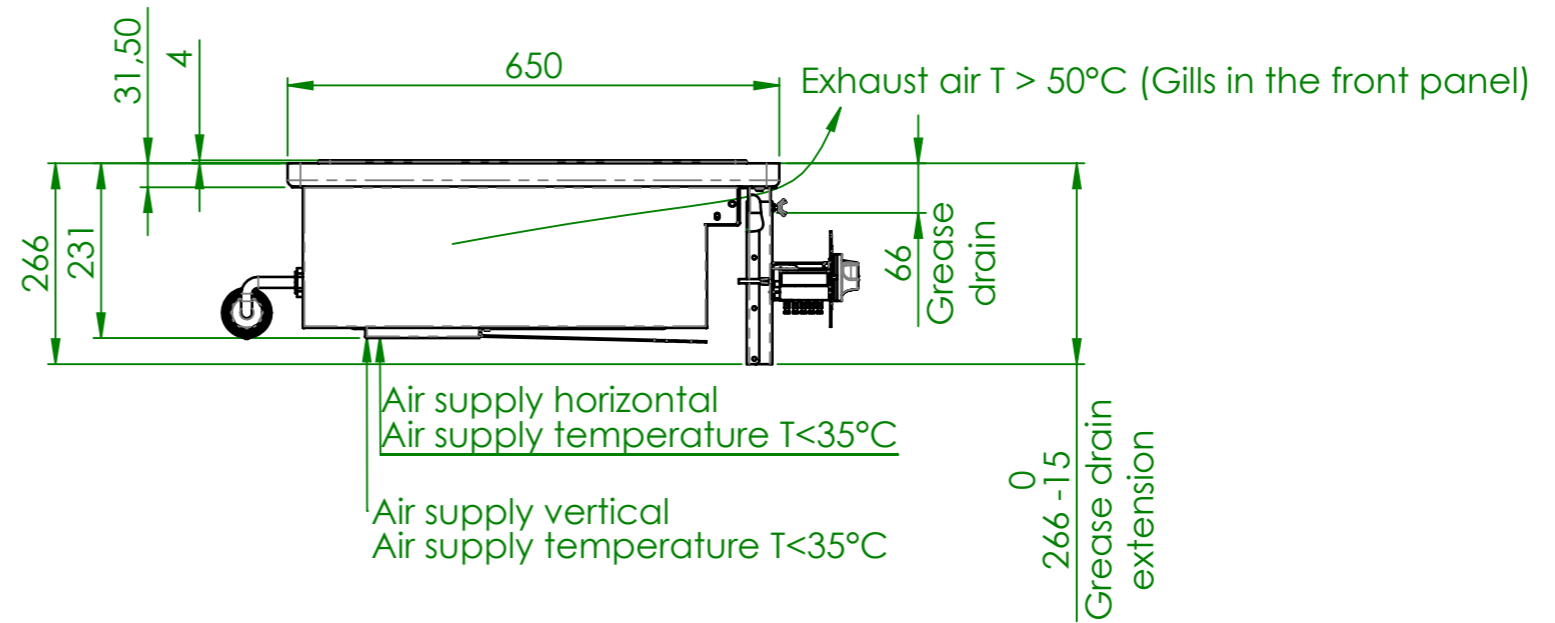
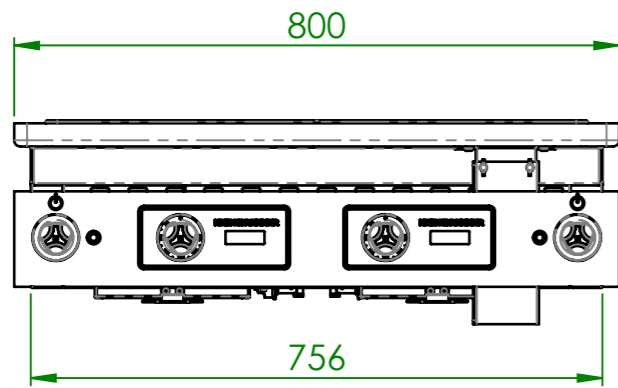

Article Nr	HZ	per HZ [kW]	Ptotal [kW]	Power connector	Circuit breaker	Residual current device	Control
EPIH	2	6	12	2x CEE 16 A, 400V~ 3L+N+PE, 6h	2x B16A 3-pol.	2x Typ A, 40A/0,03A 4-pol.	Digital

VDI 2052 Heat emission	per HZ [kW]
Qdirect	1,47
Qlatent	0,37
Qmoisture	0,54

Verwendungsbereich	Toleranz nach DIN ISO 2768-mK	Oberflächen DIN ISO 1302	Maßstab: 1:10	Gewicht: 110 kg
Name	Datum	French Electric Plancha "NIZZA"		
Bearb. W.K.	18.02.2026	EPI(BH)_eng		
HEIDEBRENNER			A3	

# EPIB

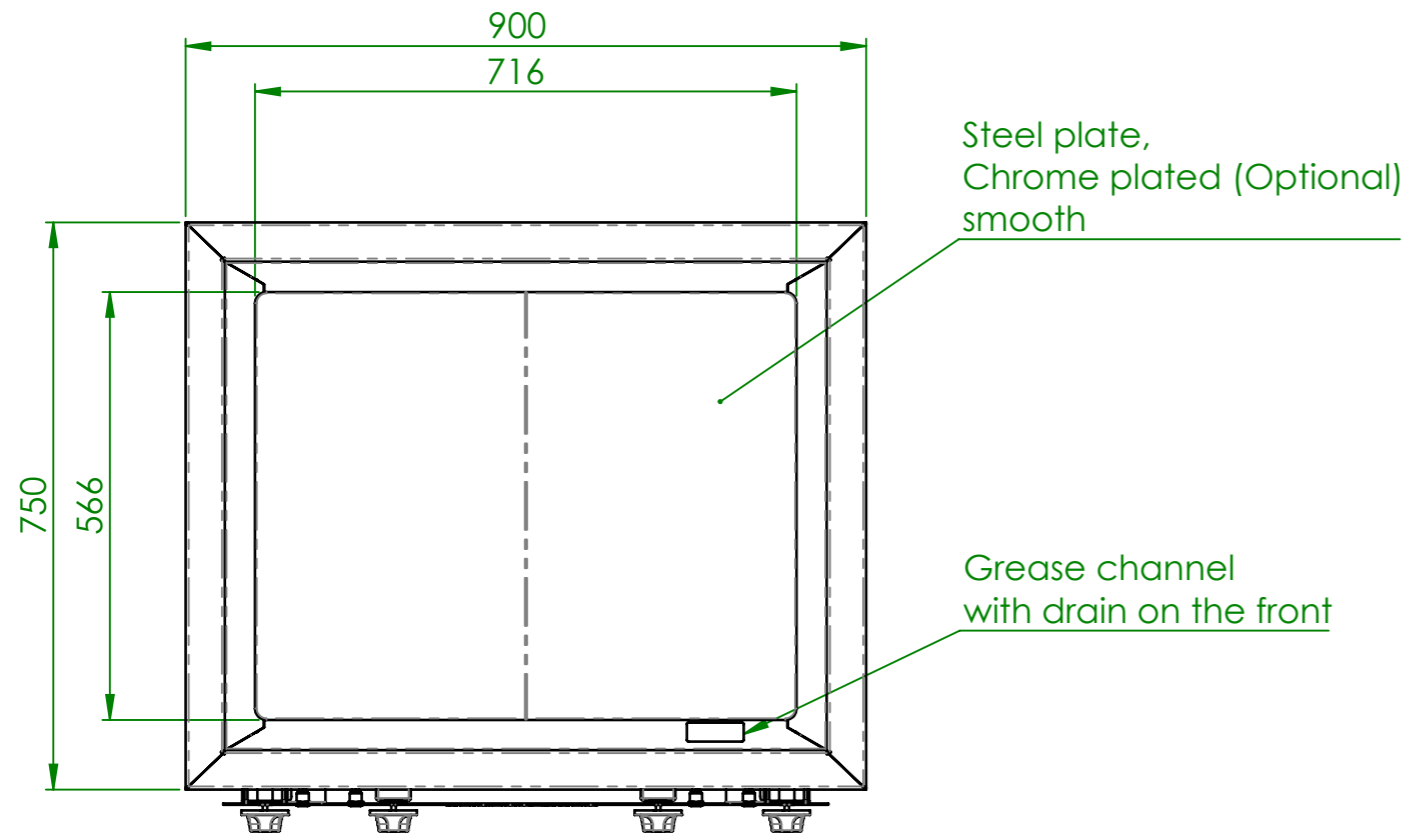
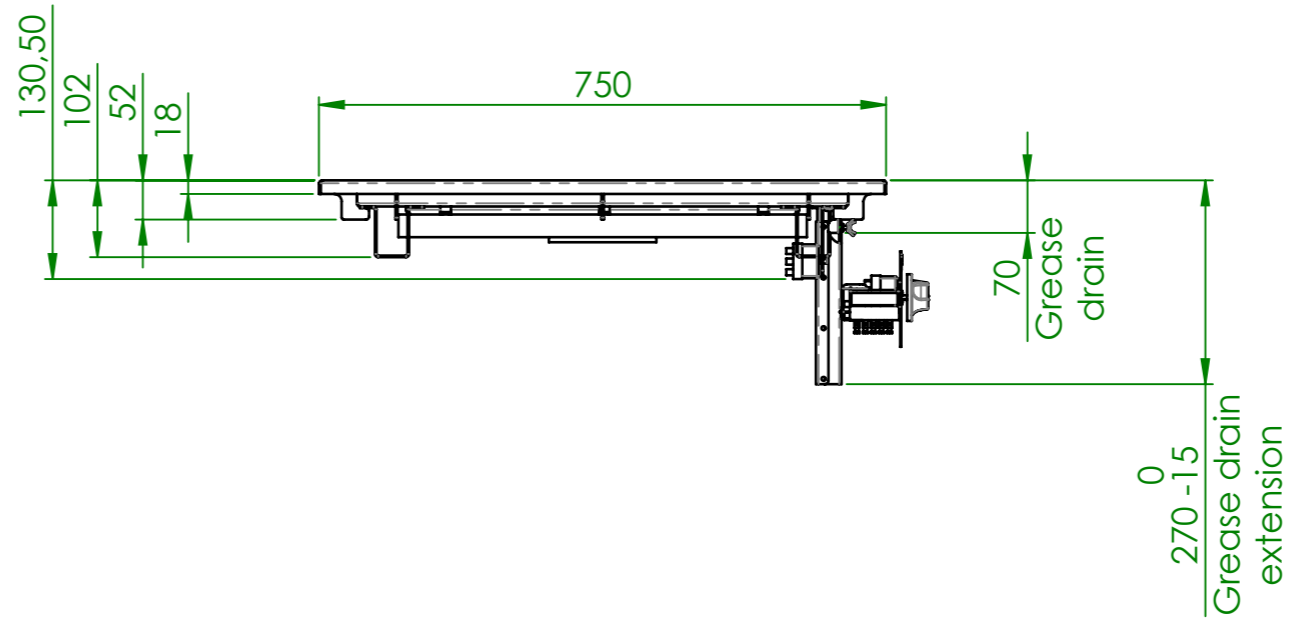
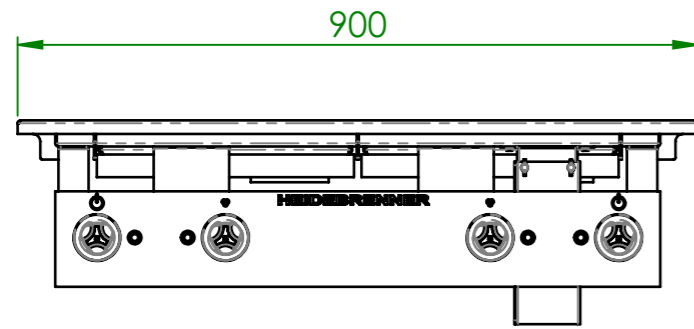

EPI(BH)-ZZ-Rahmen(Optional)

EPIB-ZZ-Blende(Optional)

ON/OFF

Temperature controller  
T=50...400°C

Grease drain  
extension(Optional)

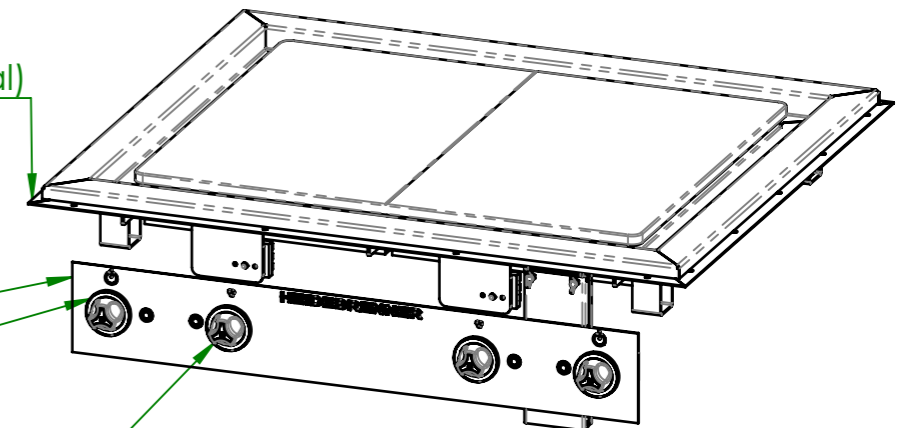

Article Nr	HZ	per HZ [kW]	Ptotal [kW]	Porcelain Clamp	Circuit breaker	Residual current device	Control
EPIB	2	6	12	2x HO7RN-F 5x4 mm <sup>2</sup> , 400V~ 3L+N+PE	2x B16A 3-pol.	2x Typ A, 40A/0,03A 4-pol.	Analog

VDI 2052 Heat emission	per HZ [kW]
Qdirect	1,47
Qlatent	0,37
Qmoisture	0,54

Verwendungsbereich	Toleranz nach DIN ISO 2768-mK	Oberflächen DIN ISO 1302	Maßstab: 1:10 Werkstoff 1.4301	Gewicht: 105 kg
Name	Datum	French Electric Plancha "NIZZA"		
Bearb. W.K.	18.02.2026	EPI(BH)_eng		
HEIDEBRENNER			A3	

# EPIB-W (WELDED)

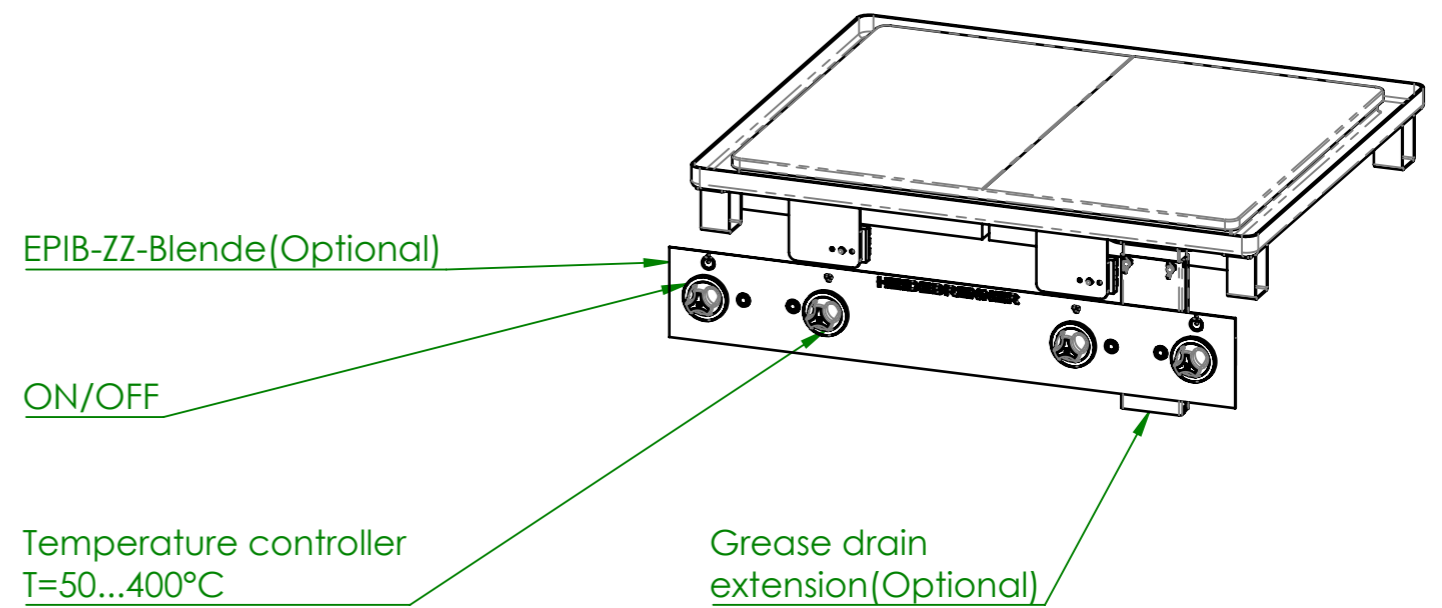
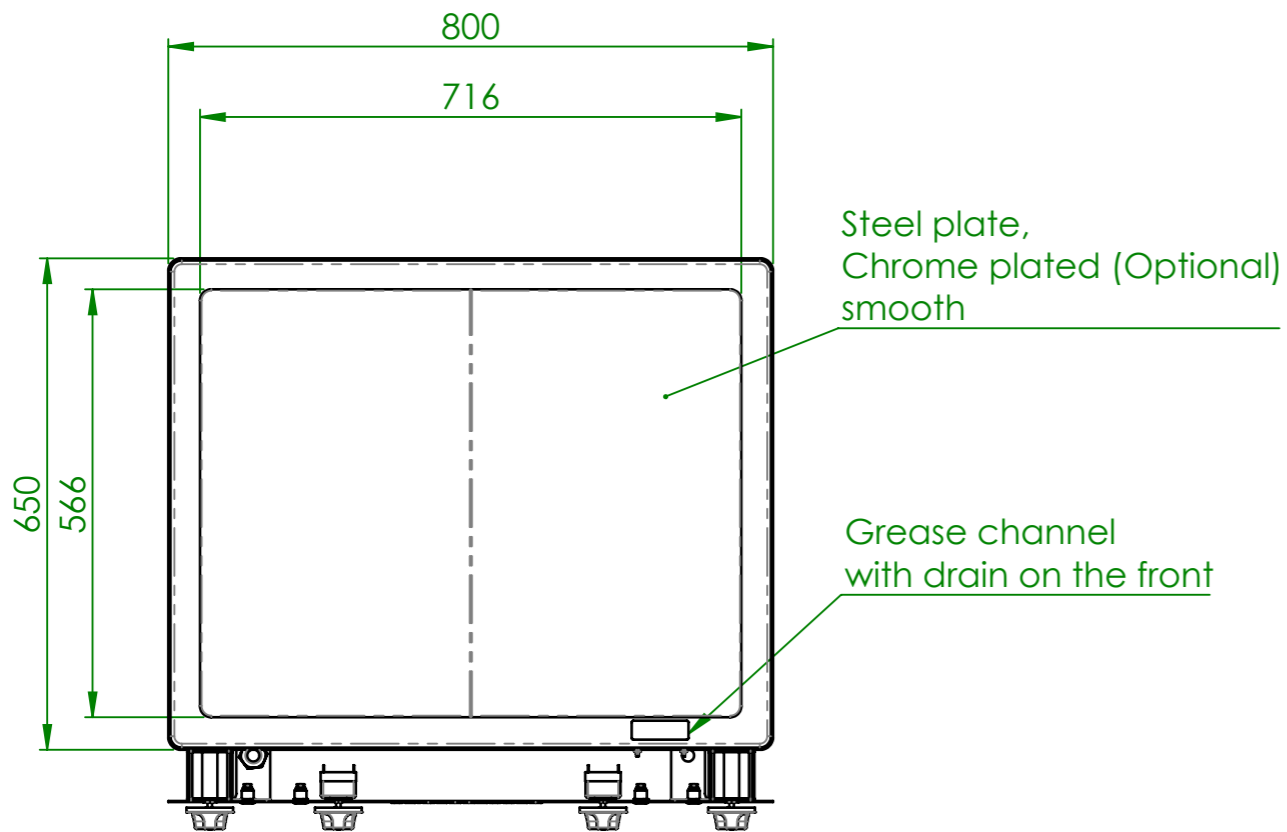
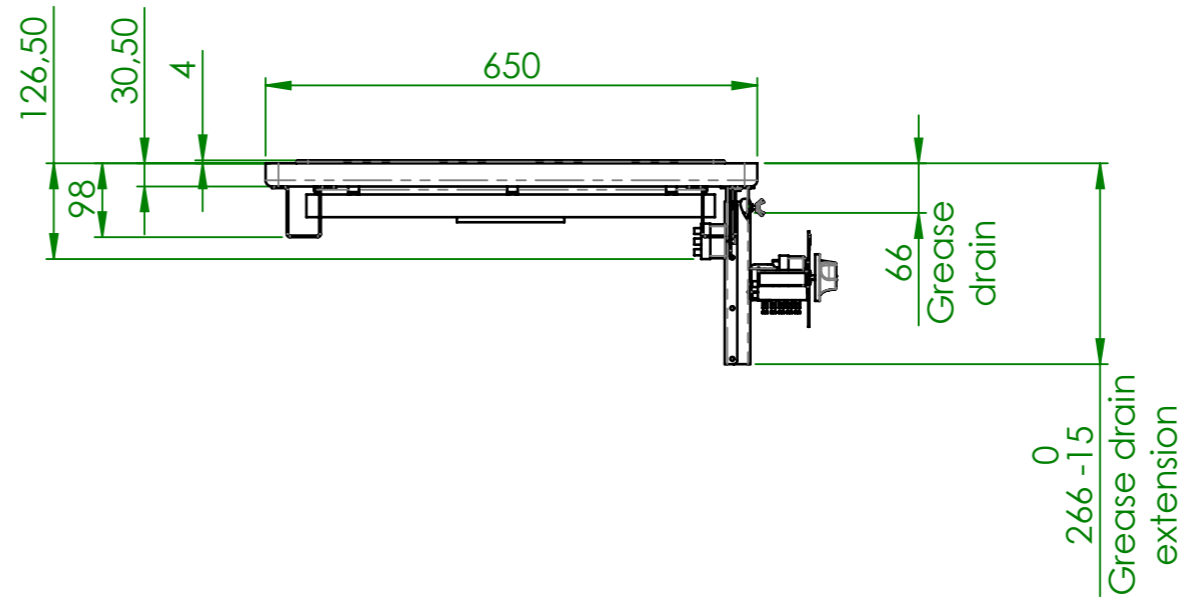
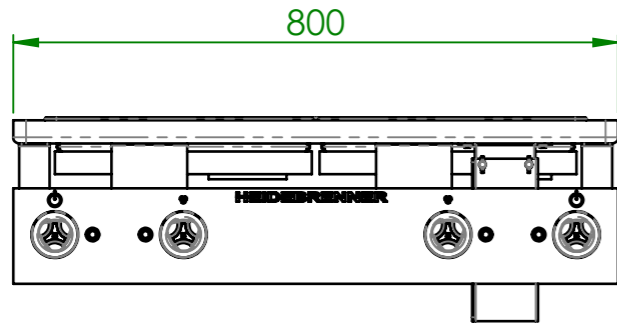

Article Nr	HZ	per HZ [kW]	Ptotal [kW]	Porcelain Clamp	Circuit breaker	Residual current device	Control
EPIB	2	6	12	2x HO7RN-F 5x4 mm <sup>2</sup> , 400V~ 3L+N+PE	2x B16A 3-pol.	2x Typ A, 40A/0,03A 4-pol.	Analog

VDI 2052 Heat emission	per HZ [kW]
Qdirect	1,47
Qlatent	0,37
Qmoisture	0,54

Verwendungsbereich	Toleranz nach DIN ISO 2768-mK	Oberflächen DIN ISO 1302	Maßstab: 1:10	Gewicht: 110 kg
Name	Datum	French Electric Plancha "NIZZA"		
Bearb. W.K.	18.02.2026	EPI(BH)_eng		
<b>HEIDEBRENNER</b>			A3	

# DROP IN INSTALLATION

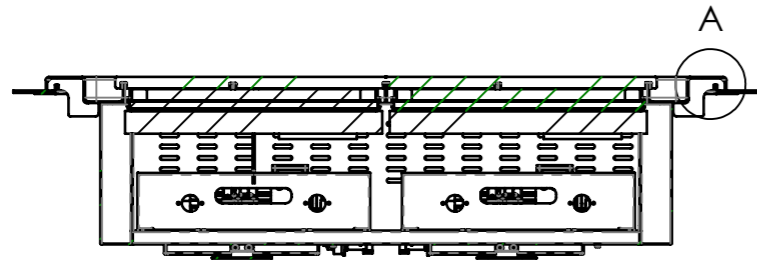

SECTION A-A

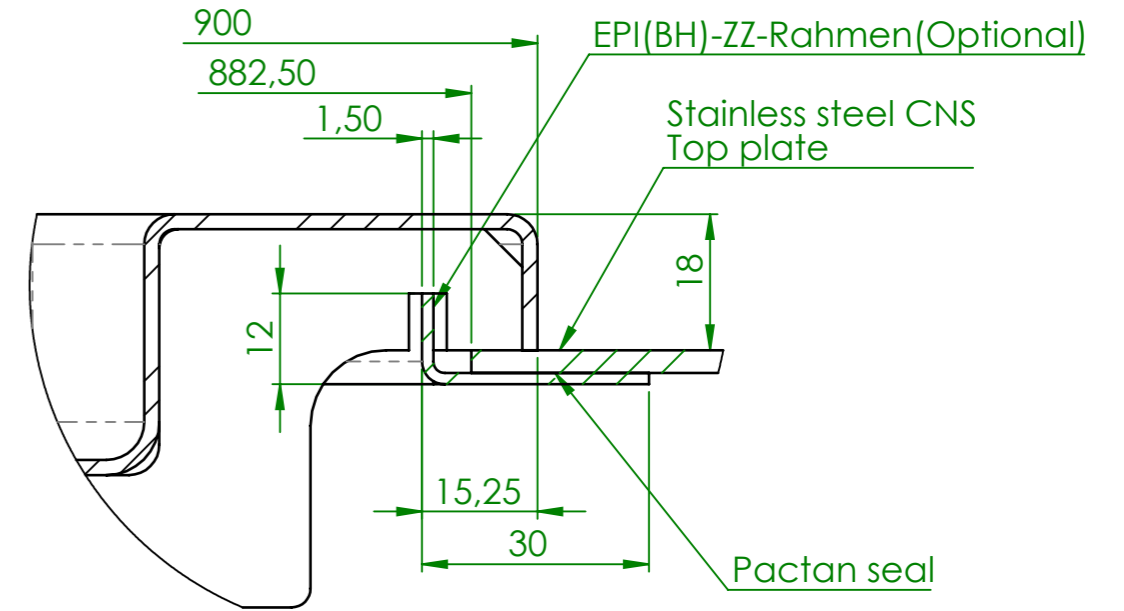

DETAIL A  
SCALE 1 : 1

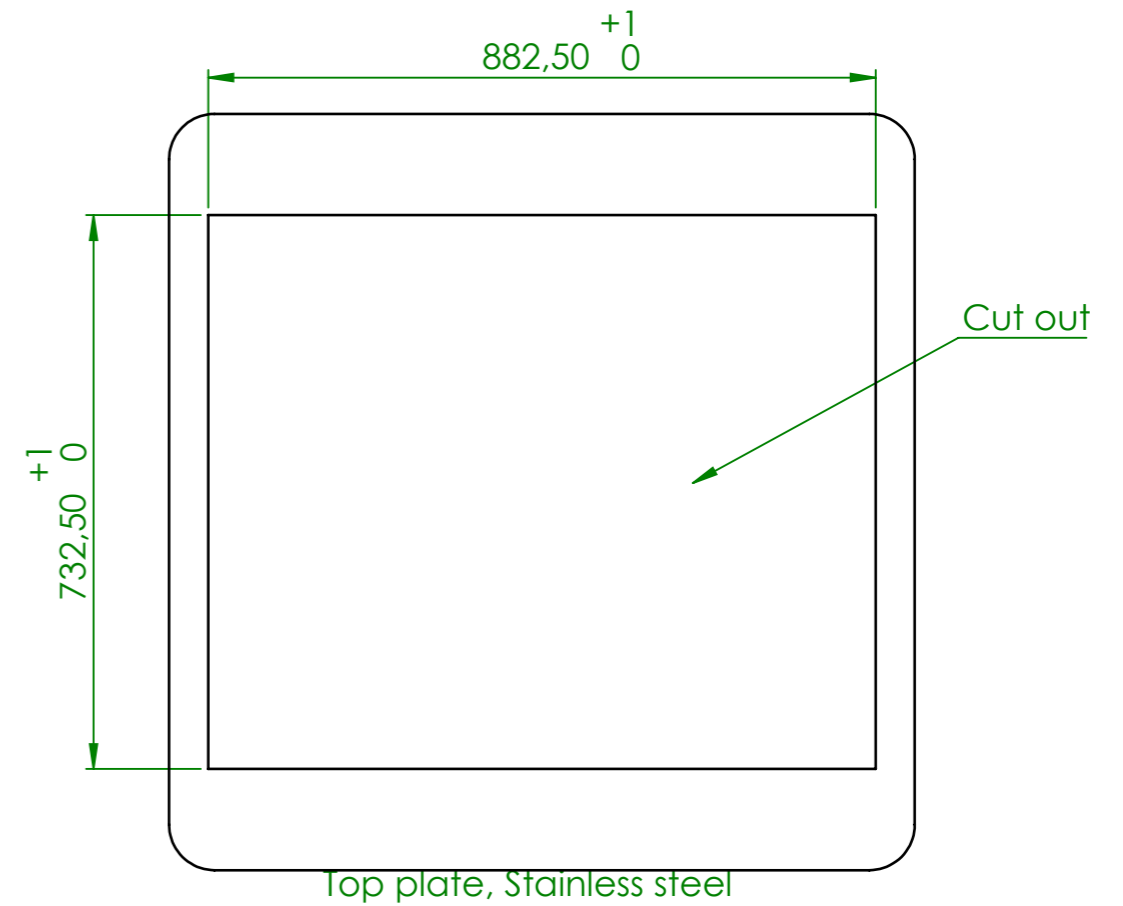
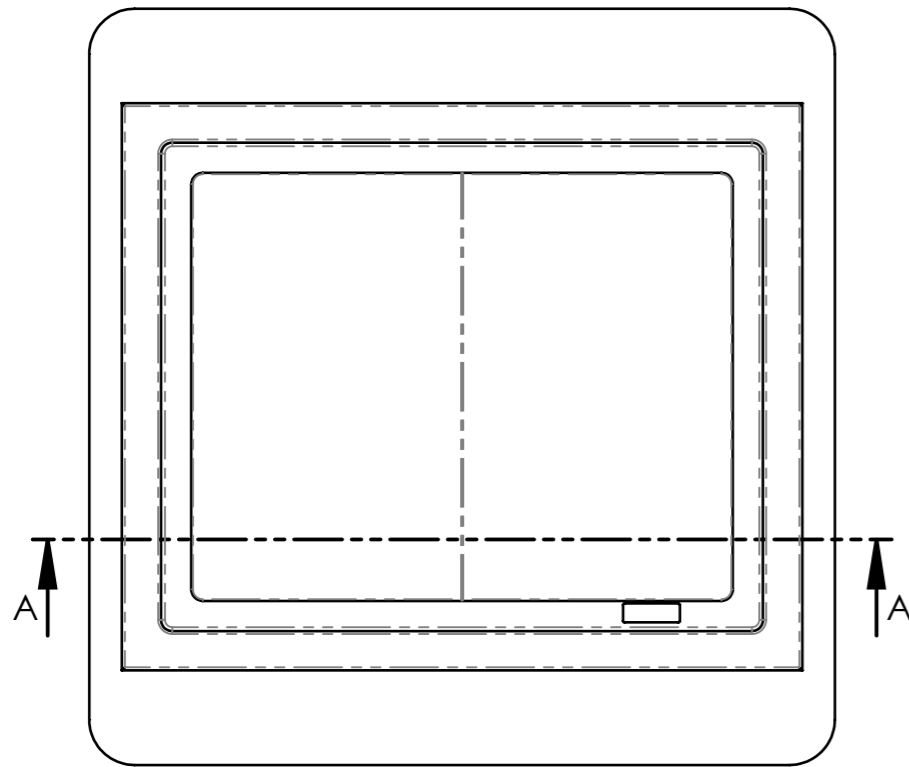

Verwendungsbereich	Toleranz nach DIN ISO 2768-mK	Oberflächen DIN ISO 1302	Maßstab: 1:10	Gewicht:
			Werkstoff 1.4301	
Name	Datum	French Electric Plancha "NIZZA"		
Bearb. W.K.	18.02.2026			
HEIDEBRENNER		EPI(BH)_eng		A3

# FLUSH MOUNTED INSTALLATION

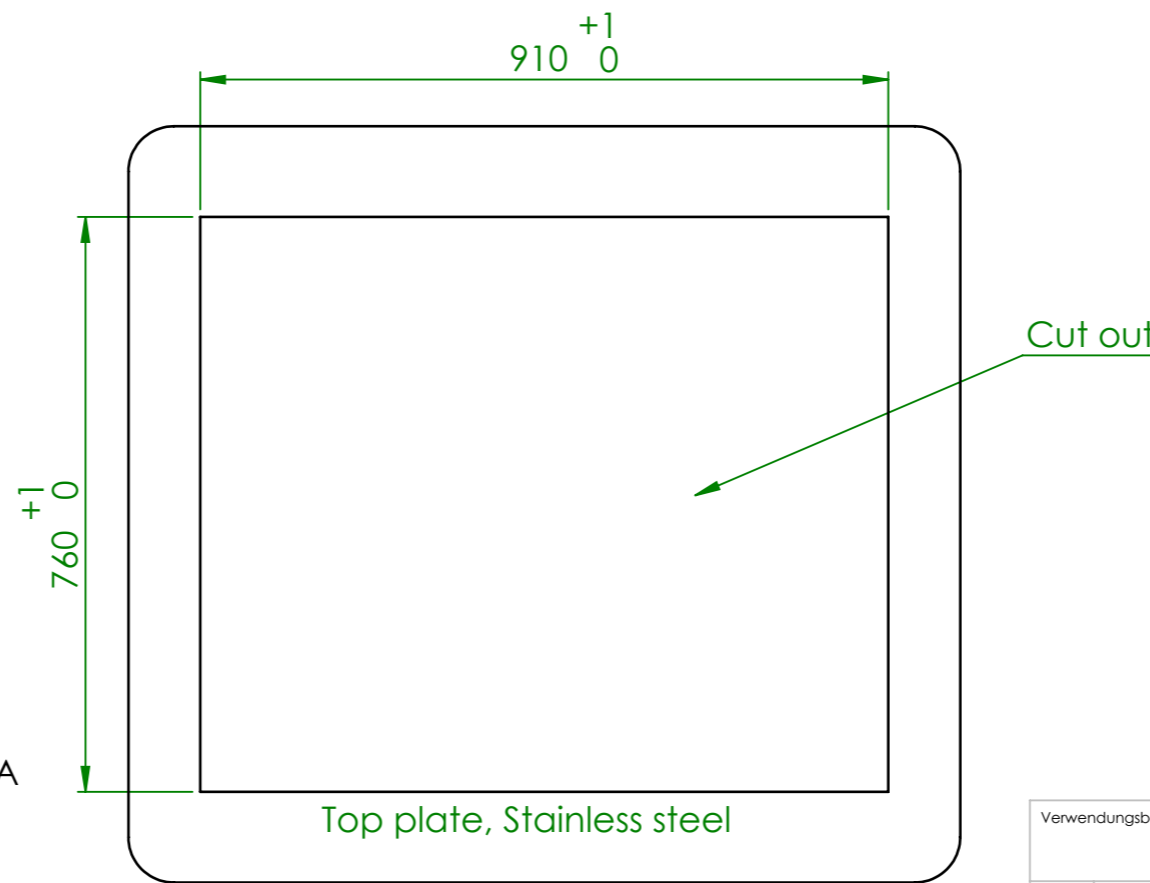
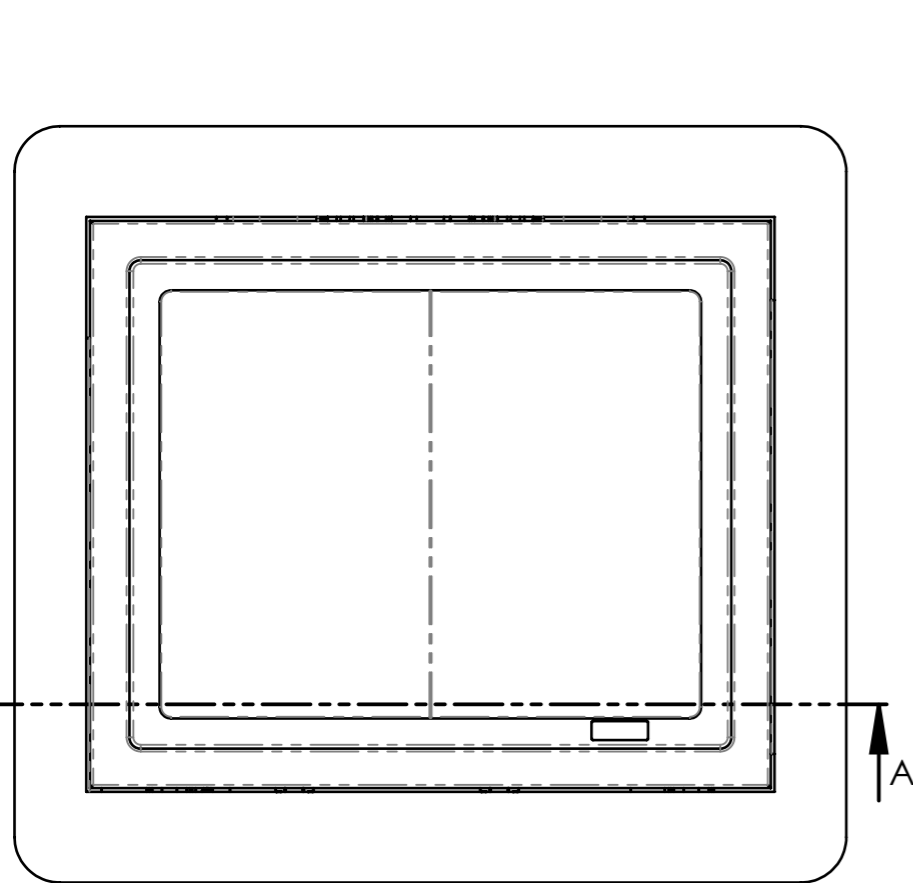
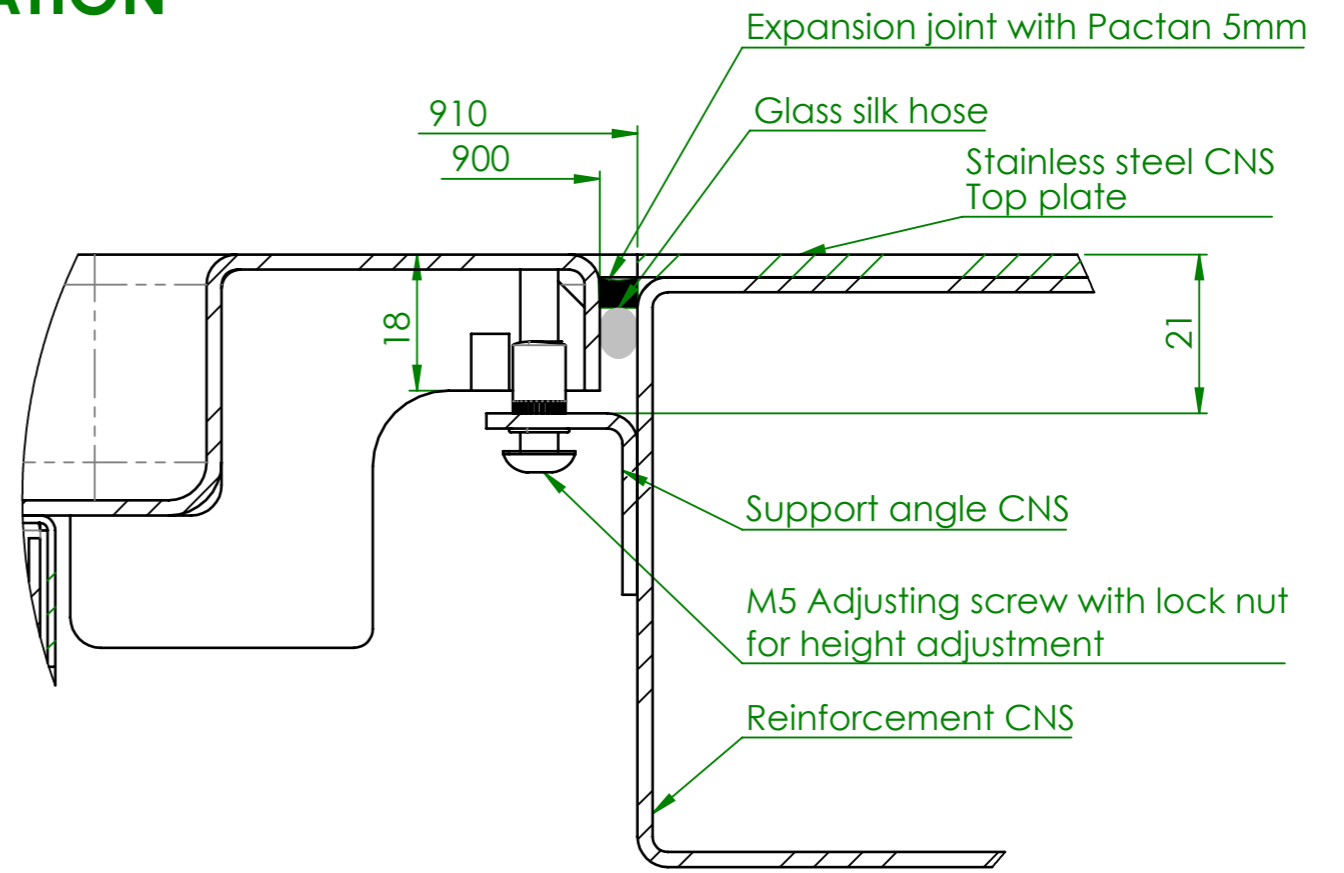
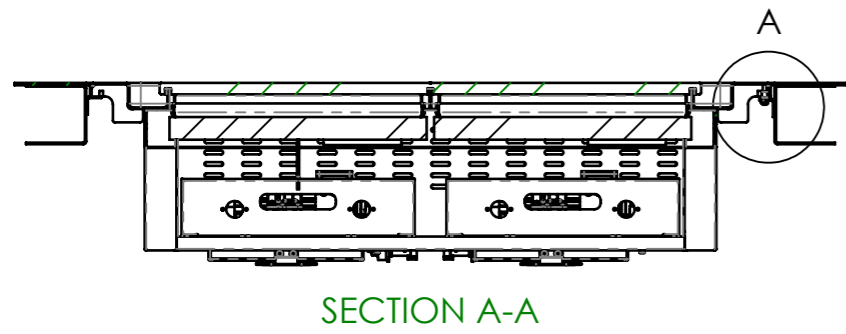

Verwendungsbereich	Toleranz nach DIN ISO 2768-mK	Oberflächen DIN ISO 1302	Maßstab: 1:10 Werkstoff 1.4301	Gewicht:
Name	Datum	French Electric Plancha "NIZZA"		
Bearb. W.K.	18.02.2026			
HEIDEBRENNER		EPI(BH)_eng		A3

# EPIH FRONT PANEL

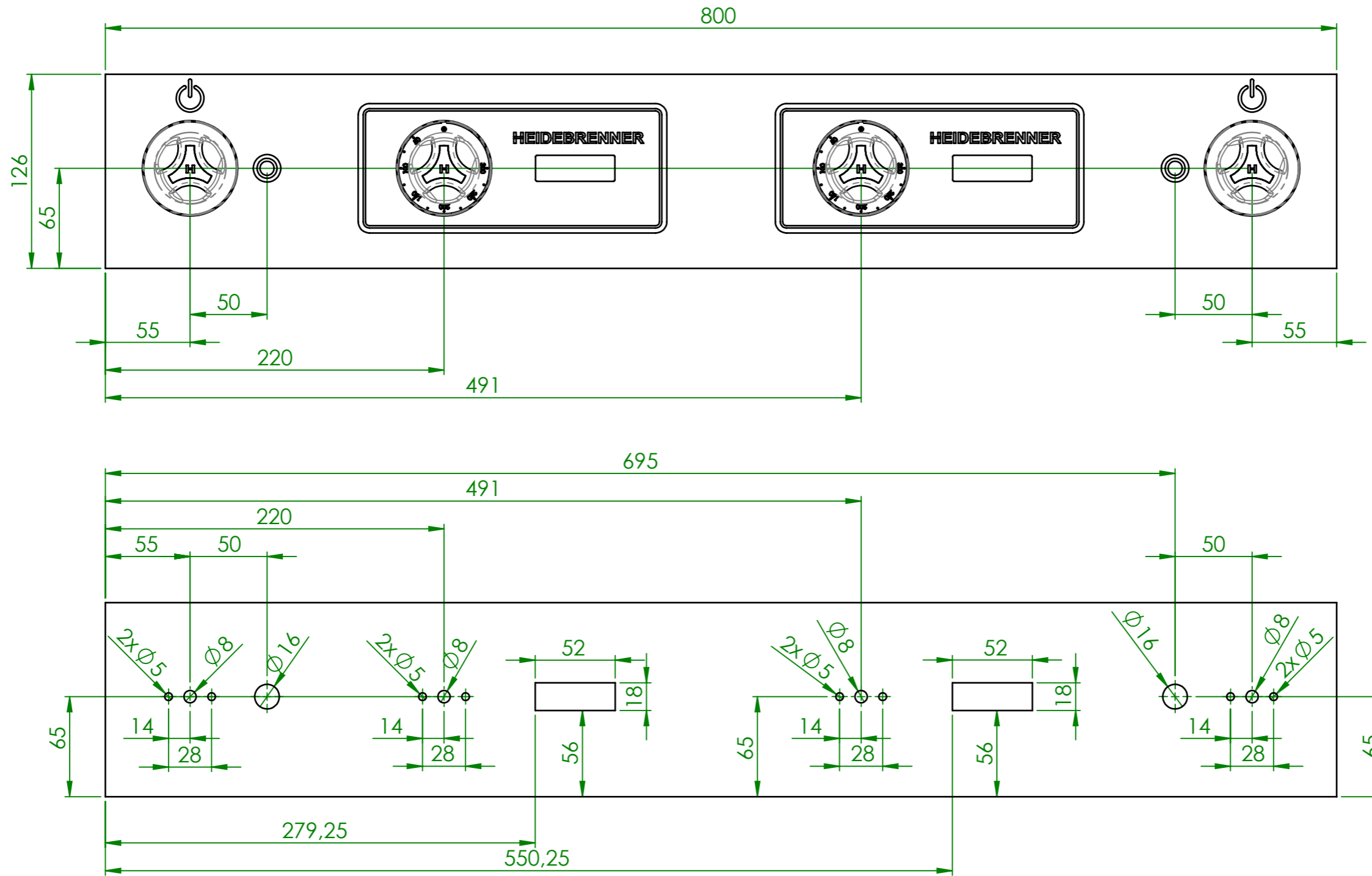

Verwendungsbereich	Toleranz nach DIN ISO 2768-mK	Oberflächen DIN ISO 1302	Maßstab: 1:3	Gewicht: kg
Name	Datum	French Electric Plancha "NIZZA"		
Bearb. W.K.	18.02.2026	EPI(BH)_eng		
HEIDEBRENNER				A3

# EPIB FRONT PANEL

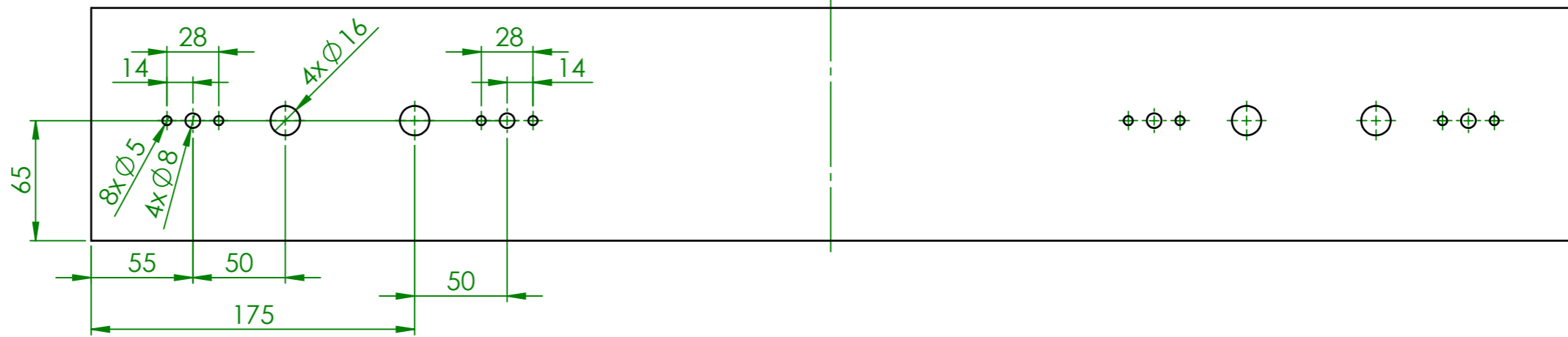
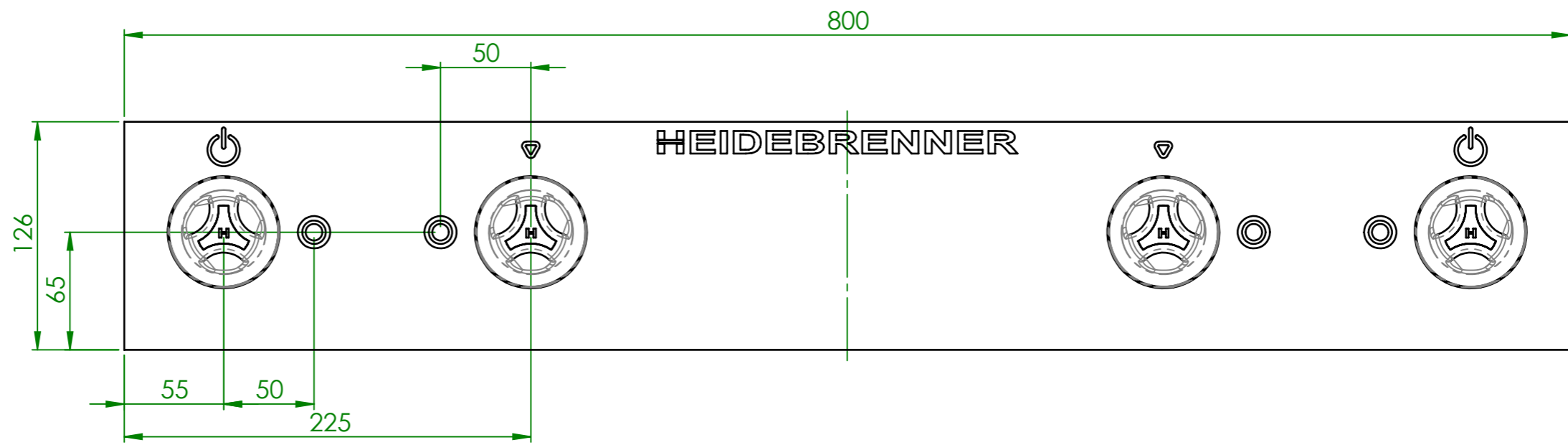

Verwendungsbereich	Toleranz nach DIN ISO 2768-mK	Oberflächen DIN ISO 1302	Maßstab: 1:3	Gewicht: kg
Name	Datum	French Electric Plancha "NIZZA"		
Bearb. W.K.	18.02.2026			
HEIDEBRENNER		EPI(BH)_eng		A3