

Verwendungsbereich 1400x900x1000	Toleranz nach DIN ISO 2768-mK	Oberflächen DIN ISO 1302	Maßstab: 1:16	Gewicht: 289 kg
			Werkstoff 1.4301	

Name	Datum	Gas Lavastein-Grill PANAREA
Bearb. M.B.	14.07.2020	

Artikel Nr.	P [kW]	Pges [kW]	Volumenstrom V [m3/h]	Gasanschluß [Zoll]	Länge Verbrauchsleitung [m] delta p=0.6mBar
GMKD	4x12,8	51.2	5.42	1"	6

HEIDEBRENNER

GMKD

A3

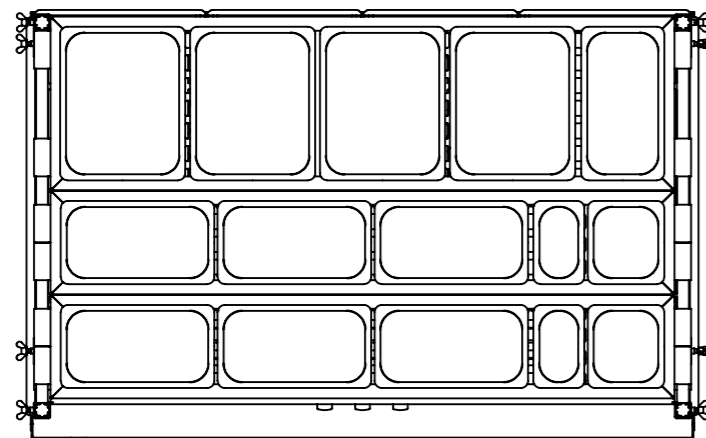
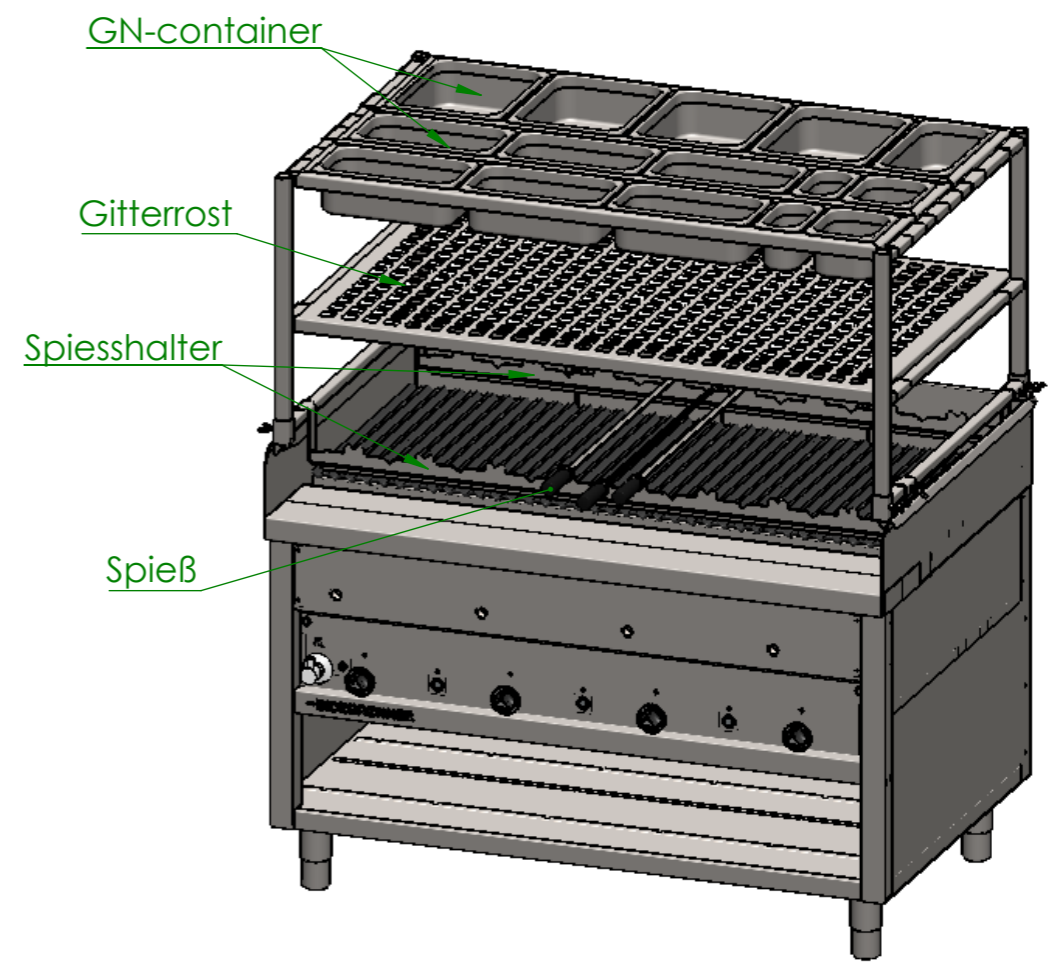
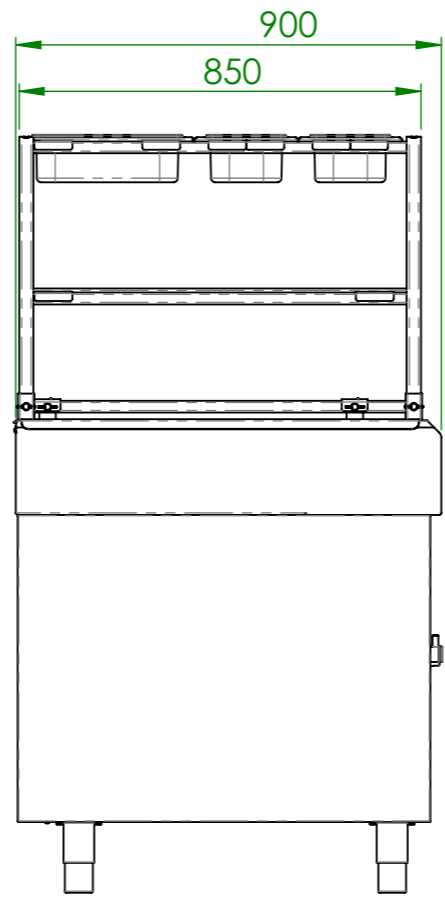
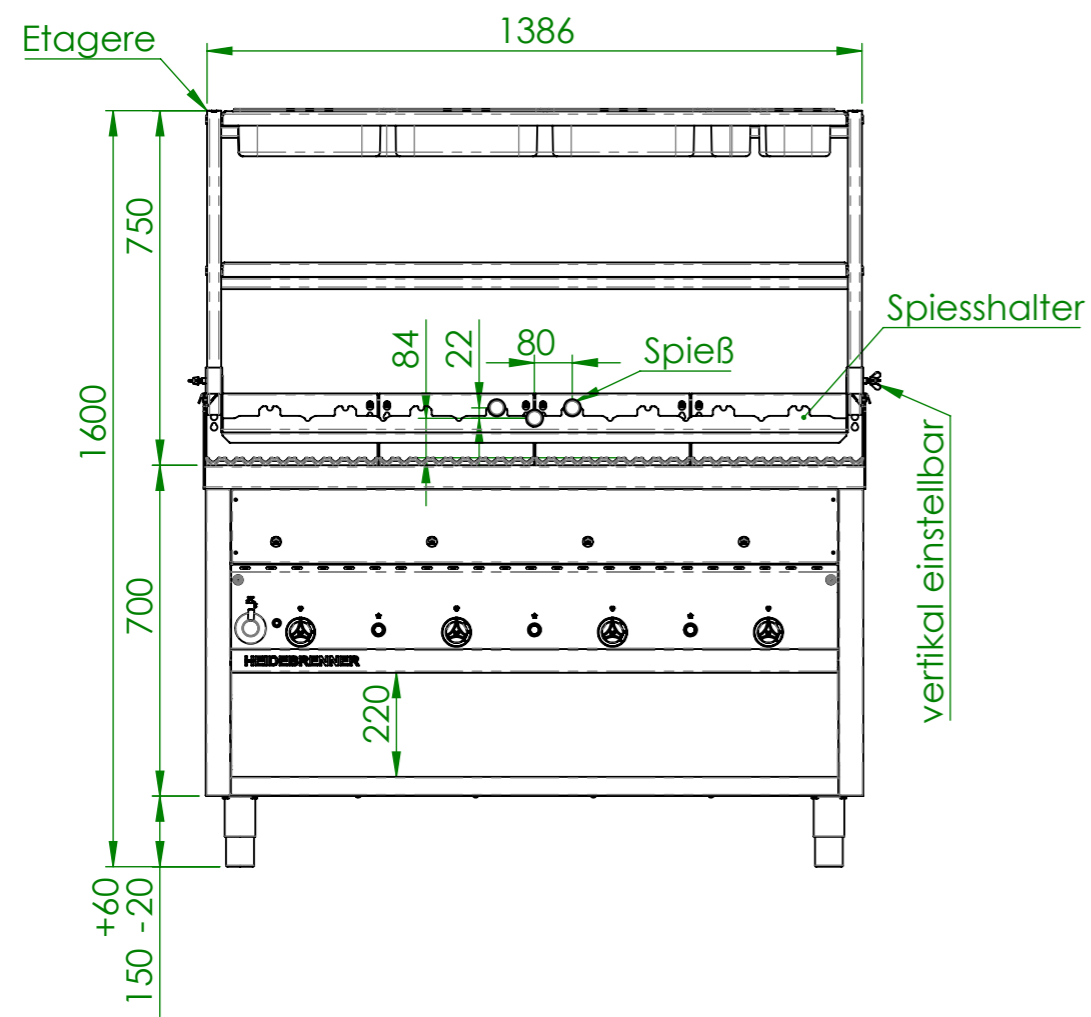

Verwendungsbereich 1400x900x1600	Toleranz nach DIN ISO 2768-mK	Oberflächen DIN ISO 1302	Maßstab: 1:16	Gewicht: 342 kg
			Werkstoff 1.4301	
Name	Datum	Gas Lavastein-Grill PANAREA		
Bearb. M.B.	14.07.2020			
HEIDEBRENNER		GMKD		A3